



Freshness
is the season
where
everything
is seasonal.



Freshness tastes good.

Since its foundation in 1989, Irinox has been acknowledged throughout the world as a specialist in blast chillers. The company has a true ability to anticipate the market's future needs and is a pioneer in presenting the concepts of blast chilling and top-quality preservation in the catering, bakery and ice cream trades. Irinox has always believed in constant research and improving technologies for perfect food preservation. An innovator in spirit, over the years it has developed cutting-edge products, offering revolutionary concepts that have set new standards on the market.

Irinox products not only provide freshness, but are also attractive, featuring new product design and simple intuitive controls.

Irinox is the freshness company, where everything is natural and the pleasure of sharing life's joys is to the fore.

"The new cultural challenge is to allow everyone to eat well every day, with fresh, healthy food. It is an ethical value not to waste food and to create more time and freedom for those who cook."

Katia Da Ros

Irinox Spa CEO and Vice President



Freshness makes us free.

Cooking is an art, passion, joie de vivre, love. **Irinox Home Collection** is designed for everyone who enjoys eating well, who places importance on quality, freshness, taste and the genuine flavour only fresh food can give. **Irinox Home Collection** takes technology and design a step further to protect a treasure that belongs to us all: the vitamins, colours, flavour and aroma of fresh food. It's like creating a fifth season that combines all these qualities, to be enjoyed when they are at their peak.



Freddy



Zero



Wave

Home Collection.

Iriinox Home Collection is intelligence, sensitivity and desire expressed in the form of five products created to put the soul into cooking. The kitchen becomes a place where health and wellbeing reign. Design is enhanced by intelligent, people-friendly technology aimed at increasingly dynamic, balanced lifestyles. For us. For nature. For the pleasure of eating together.



Vinoteca

Freddy multi-function built-in blast chiller

Fresco® Élite multi-function on-the-counter blast chiller

Zero vacuum sealer

Wave water dispenser

Vinoteca wine cooler



Freddy. The multi-function built-in blast chiller

FRESHNESS IS AT HOME HERE.

Freddy is the first blast chiller made for domestic use, with an essentialist design that's appealing in any kitchen. Freddy is a dream come true: a time machine that we can put to use to lock the succulence into food at just the right moment and keep it there over time. Flavour, vitamins, colour and consistency can overcome space and time so that they can always be enjoyed at their best.



The multi-function on-the-counter blast chiller.

We are proud to introduce you to Fresco® Élite, the appliance for magic, swift food chilling. You're sure to fall in love at first sight with its exclusive design, and once you've tried it, you'll never again want to do without it in the kitchen.

Fresco® Élite is the only household appliance that can triple the shelf life of fresh or cooked food, inspiring you to unleash your culinary potential and create flavours never tasted before.



A new quality of life.

Stopping time does not just mean enjoy one long period when all food is always "in season", it also means having more time for ourselves as we can plan dishes to be ready when we get home, leaving time to savour the company of friends. With Freddy & Fresco® Élite there's always someone there to see to everything.



Zero waste.

The blast chiller helps reduce waste because food is preserved at its freshest with its quality maintained, tripling its shelf life. That means almost nothing is discarded.

Extended freshness.

You can preserve the freshness of raw materials such as seasonal fruit and vegetables perfectly. Food that maintains its nutrients intact is healthier and can be enjoyed at any time of the year. With the blast chiller healthy eating becomes a good habit.

Time saving.

Thanks to the blast chiller you can prepare food in advance, cooking when you have time and eating it when you want. You can also do the shopping once a week, preserving the food and warming it up again as and when needed. Just what you've always wanted.

The pleasure of time with friends.

You can use the blast chiller to prepare everything in advance and invite friends at the last minute, offering them the quality and variety of a meal planned days before. Having everything ready means you spend less time in the kitchen: now you can really savour spending time with friends.





We've re-invented time.

The blast chiller is the only household appliance that blast-chills food after cooking, quickly deep-freezes and thaws it in a regulated manner, cooks meat and fish at low temperatures, allows bread, pizza and flatbread to prove, presents dishes hot and ready to serve, holds them at ideal temperatures and cools wine and other drinks.



9 WAYS TO LIVE WELL.

Freddy unites blast chilling and slow heating, managing temperatures of -35 °C to +80 °C and providing 9 innovative functions. Freddy is Irinox-patented technology.

-  **Blast chilling to +3 °C**
-  **Shock freezing to -18 °C**
-  **Gentle freezing to -18 °C**
-  **Controlled thawing**
-  **Drinks cooling**
-  **Customized preservation**
-  **Low-temperature cooking**
-  **Natural proving**
-  **Ready-made dishes**

Good and fast,
together for the first time.

Quality is
a dish best served cold.



BLAST CHILLING TO +3 °C

Quickly lowers the core temperature of just-cooked hot food to +3°C. By quickly dropping through the +40 °C to +10 °C temperature range, the blast chiller blocks evaporation and prevents the proliferation of bacteria. Ideal for preserving the quality, fragrance, colours and aromas of food, tripling its shelf life.

Any cooked food can be blast-chilled and kept in the fridge for up to 7 days.



Find out more about
Blast Chilling



SHOCK FREEZING TO -18 °C

As the blast chiller quickly reaches a temperature of -35 °C inside the cabinet, the shock-freezing cycle rapidly takes food to -18 °C at the core.

In this way preservation is perfect and when thawed food will be exactly as it was when fresh.

Shock-frozen food can be kept in the freezer for up to 6-8 months.



Find out more about
Shock Freezing

Find out more
on blast chilling.



GENTLE FREEZING TO -18 °C

Ideal for hot and/or delicate food, this cycle lowers the temperature to +3 °C, which gradually drops to -18 °C at the core: the result is rapid but non-aggressive freezing.

Essential for delicate food that must be kept in the freezer.



Find out more about
Gentle Freezing



Like before,
more than before.

Temperature
is no longer just an ideal.



CONTROLLED THAWING

The blast chiller thaws food rapidly by means of gentle ventilation that holds micro-crystallised water inside the food. Food that has undergone controlled thawing maintains its quality and fragrance perfectly, just as if it were fresh and had never been frozen.

Ideal for all food, even the most delicate.



Find out more about
Controlled Thawing



DRINKS COOLING

It takes just a few minutes to chill wine, cool soft drinks and offer guests fresh aperitifs. The blast chiller cools bottles at a speed of approximately +1 °C per minute, giving you the pleasure of enjoying drinks at their ideal temperature.

You're always ready when unexpected guests turn up.



Find out more about
Bottle Cooling

Delicacy above all.



CUSTOMIZED PRESERVATION

This is the function that adapts to the most modern needs and meets all requirements, as it allows you to choose the ideal temperature, from -20 °C to +80 °C, **to preserve your food, even the most delicate**, such as home-made ice-cream (-12 °C), or fresh fish (+2 °C), and to melt chocolate like in a bain marie (+40 °C).



Find out more about
Customised Preservation



Great dishes demand patience.

An exciting phenomenon.

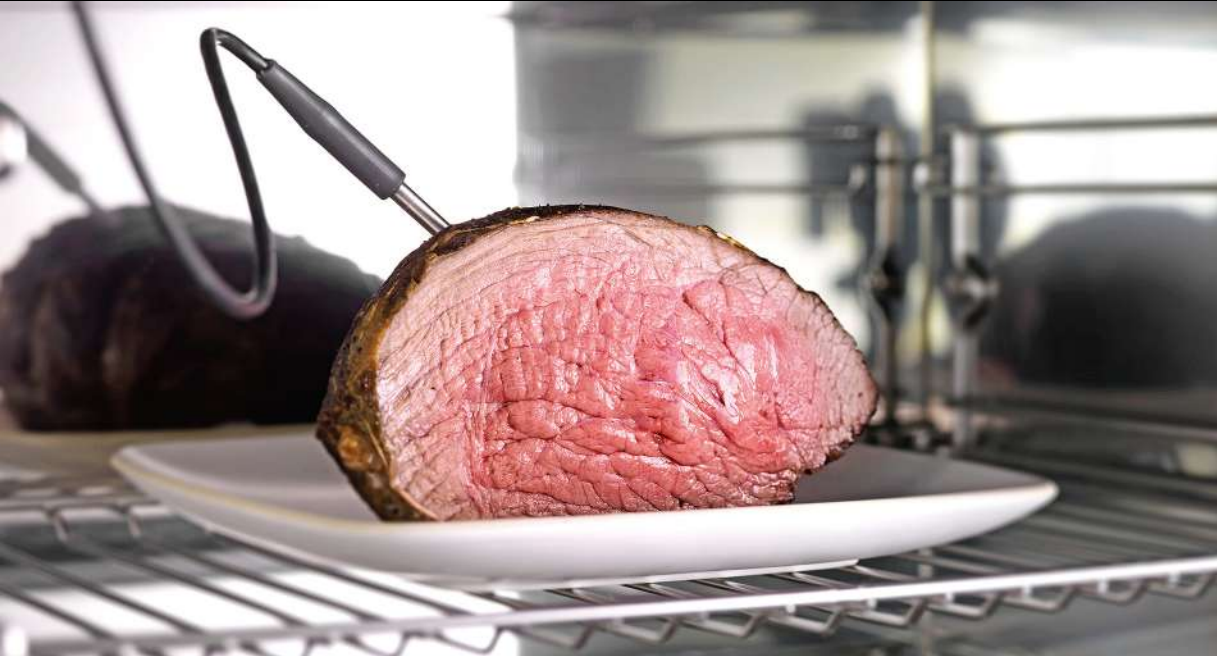

LOW-TEMPERATURE COOKING

Low-temperature cooking gently cooks meat and fish, never exceeding a core temperature of +70 °C. It enhances flavours, maintains a tender consistency and ensures uniform cooking.

For cooking meat and fish, bringing out their tenderness and flavour.



Find out more about Low Temperature Cooking



NATURAL PROOFING

Controlled proofing at a constant temperature allows the yeast in bread, pizza and brioche dough to develop perfectly. The blast chiller makes sure all proved items have an intense flavour, a light structure and just the right crumbliness as well as being easy to digest.

Makes bread, pizza and brioche dough easier to digest.



Find out more about Natural Proofing

Home, sweet home.



READY-MADE DISHES

Your food is piping hot just when you want it. Simply programme the time you will be coming home and dishes are first held as if in the fridge, then taken to the pre-set heating temperature.

Enjoy the convenience of coming home to find your meal freshly oven heated.



Find out more about Ready-made Dishes

Your new life with the blast chiller.

It's incredible how the blast chiller can change your habits. Time is the new currency, to spend as you like, a currency that will earn you a better quality of life.



The first produce from your garden, even in December.



A healthy snack always to hand.



Entirely safe sushi and raw fish, at home.



Ready-to-serve finger food for those last-minute happy hours.



A stock of your favourite dishes always ready.



Home-made bread, fresh every day.



Shop when you want, not when you must.



Cook once a week and enjoy your leisure time.

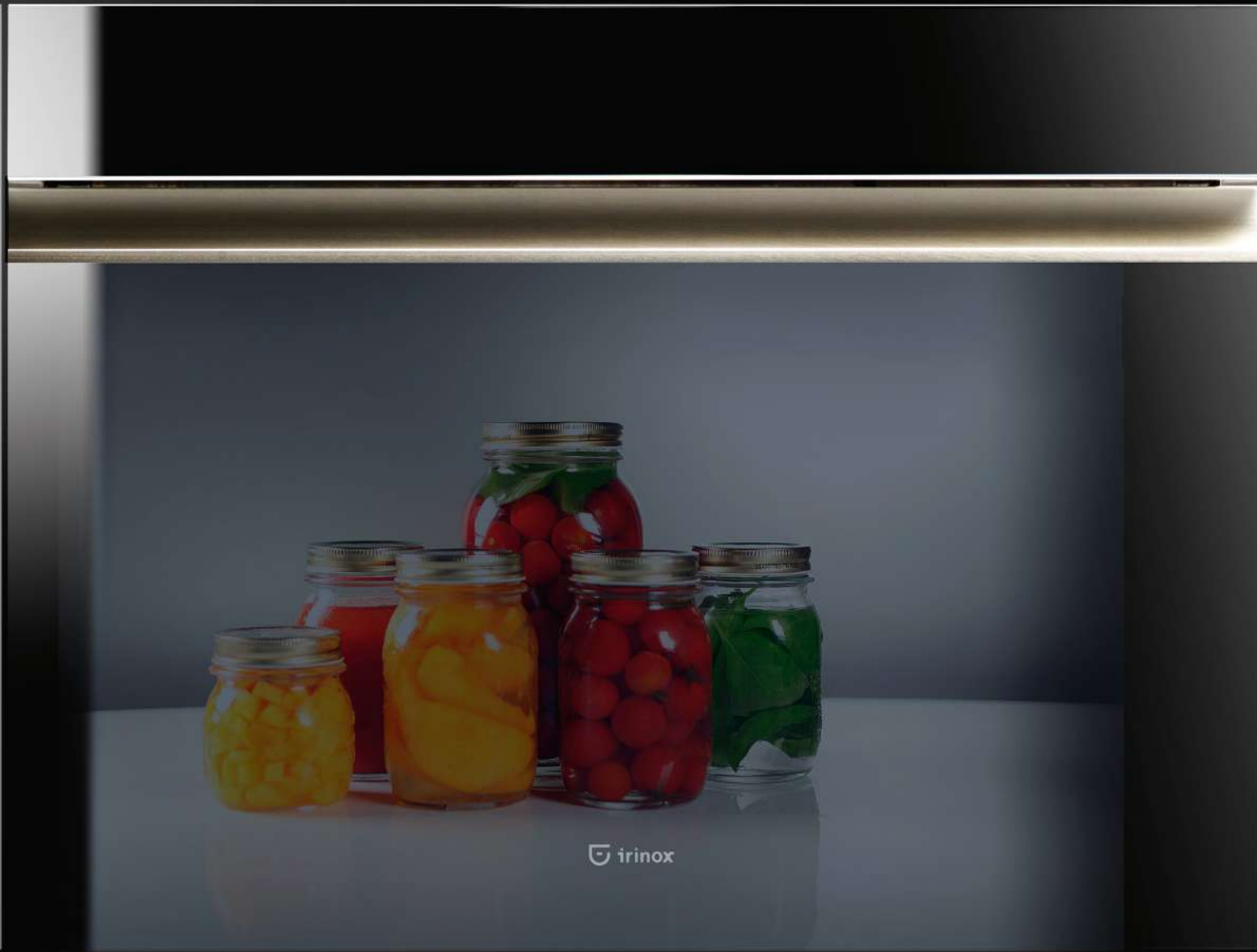

Zero. Vacuum sealer

ATTRACTIVE ON THE OUTSIDE, FRESH ON THE INSIDE.

Zero is the first built-in professional-standard vacuum sealer that can reach a vacuum close to absolute zero, which truly slows down the ageing and oxidation of food.



This is a superior quality, absolutely natural process that is extremely effective in keeping the properties of food intact longer, without compromising in terms of nutrients.



Viva vacuum.

Zero is indispensable for vacuum cooking and preserving food in the fridge up to five times longer. The soft-touch control panel is used to quickly set three different degrees of vacuum and select pre-set cycles for marinades, meat ageing and liquids. Zero is extremely flexible: it adapts to different needs, even the most demanding, to create customised settings to suit the type of food and the required result. Zero also makes it possible to prepare food for sous-vide cooking in water, with Freddy or in a steam oven.

SIX PROGRAMMES, A THOUSAND SOLUTIONS

- Gentle vacuum
- Preservation vacuum
- Extreme vacuum
-  Meat ageing
-  Marinating
-  Liquids

A gentle touch
for even the most delicate dishes.

A very special atmosphere.



••• GENTLE VACUUM



For vacuum packing delicate food such as soft cheese, cakes, salads and anything that easily crushes.
This function is used to hermetically seal vacuum bags by simply heat sealing them without necessarily creating a vacuum.

••• PRESERVATION VACUUM



This function is used for vacuum packing most food, such as cooked vegetables, fruit, tender meat, pasta and liquids like soup, cream, sauces and jam.

Get sucked in.



EXTREME VACUUM



The ideal programme for vacuum packing solid food such as raw vegetables, hard cheese and cold cuts, and for preparing food for perfect sous-vide cooking.

Zero.



Not so tough any more.

All the flavour
without wasting time.



MEAT AGEING

Zero's meat ageing programme takes just a short time to tenderise meat. With this procedure the meat undergoes repeated vacuum cycles so that its fibres become softer and ready for cooking. The vacuum cycle can be repeated 2 to 15 times.



MARINATING

This programme is used to marinate food perfectly. The vacuum created in this cycle ensures that the oil and spices in a bag containing meat, fish or vegetables are quickly absorbed to flavour the food. On average, marinating lasts 5 minutes, but the time can vary from 1 to 15 minutes according to the cut of meat or size of the fish.

The art of giving shape to liquids.



LIQUIDS

The vacuum programme for liquids is used to seal bags containing cold liquids, such as soup, sauces, ragout or jam. Designed to help you create a personal stock of seasonal jam, preserves and pickled produce. It's the ideal function for mothers who want to prepare their own baby and infant food.



Zero.



Wave Hot&Cold. Water dispenser

MICROFILTERED WATER, FROM THE FIRST TO THE LAST DROP.

Wave is a domestic water dispenser that connects directly to your home's mains to provide instant premium microfiltered water, chilled, sparkling, room temperature or hot.

Using an advanced filtration system that removes up to 99% of contaminants, Wave gives you pure water from the first to the last drop.

Wave's purified water is not just free of pollutants but also tastes great and is totally odourless, ensuring every sip is exceptionally fresh.



THE LUXURY OF SIMPLICITY.

A simple pleasure to look forward to:
a glass of water always to hand.

-  Ambient temperature
-  Sparkling chilled
-  Chilled
-  Hot water

Pure water has a flavour. Actually four.

Wave delivers four types of microfiltered water: room temperature, chilled, chilled carbonated, and hot at 85°C.

Wave produces room temperature water that is purified up to 99.9% and comes with three temperature settings and an adjustable carbonation system to give you water from 5° to 12°C and with just the right degree of sparkle.

Teas and herbal teas should be brewed at the correct water temperature.

Wave delivers water at 85°C, which is the perfect temperature for preserving the aroma molecules and all desirable compounds that should go into your cup*.

*Source: sorgentenatura.it

It's as easy
as drinking a glass of water.



Wave is extremely easy to use; its display has four simple buttons, one for each function. It's easy to select and immediately receive the type of water at the required temperature.



 irinnox

Vinoteca. Wine cooler

STYLE IS A QUESTION OF DETAILS.

Vinoteca is the single or double temperature, free-standing or built-in wine cabinet by Irinnox for holding every type of wine at the ideal temperature. The electronic display constantly shows the actual temperature so that it can be finely controlled.

The toughened glass door is UV treated to protect the bottles from light while they are on view. The elegant concealed handle makes the cabinet easy to match with any appliance in the kitchen.



**A WINE COOLER,
AN AFFORDABLE LUXURY.**

Vinoteca comes with elegant, pull-out wooden shelves that make it easy and to locate remove bottles.

**A pleasure for the palate
and the eyes.**

Vinoteca can be placed upright or under a work surface so it will integrate perfectly with any kitchen decor. The standard configuration has a capacity of 36 bottles arranged on 5 shelves. The grille provided can be used to create a customised setup according to need, and can contain up to 44 bottles lying down.

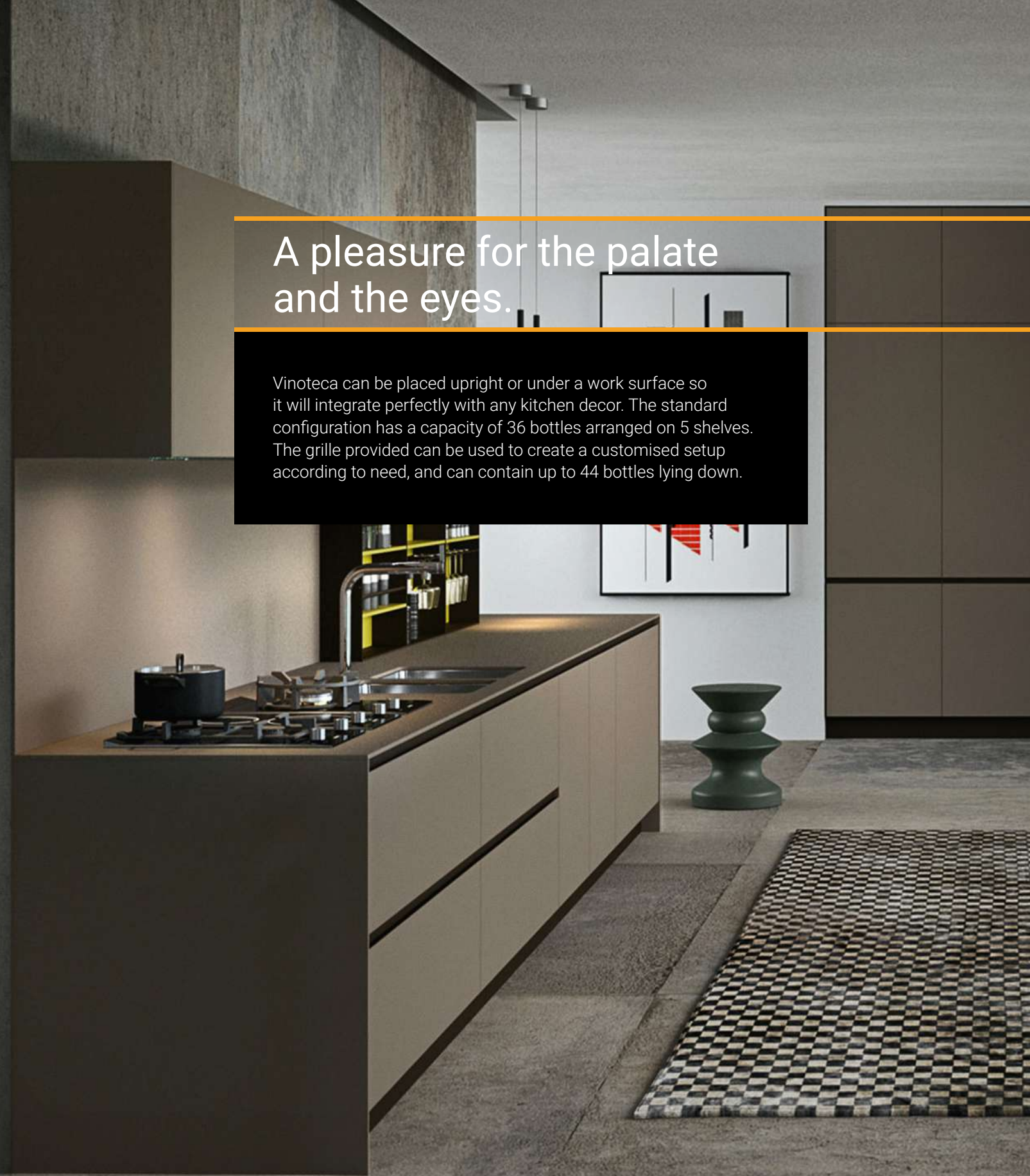



RED OR WHITE? YOUR PLEASURE IS SERVED.

To preserve wine properly, the temperature of the upper compartment is set to +7 °C (serving temperature for white wine), so as to achieve approximately +14° or +15 °C in the lower compartment.



**IRINOX LAB. A LOVE OF GOOD THINGS,
A PASSION FOR BEAUTY.**

Irinox LAB is the place created by Irinox Home to shape its brand and bring it to life. It's a real laboratory and a showroom that's also a lounge where people can meet, exchange and compare ideas.

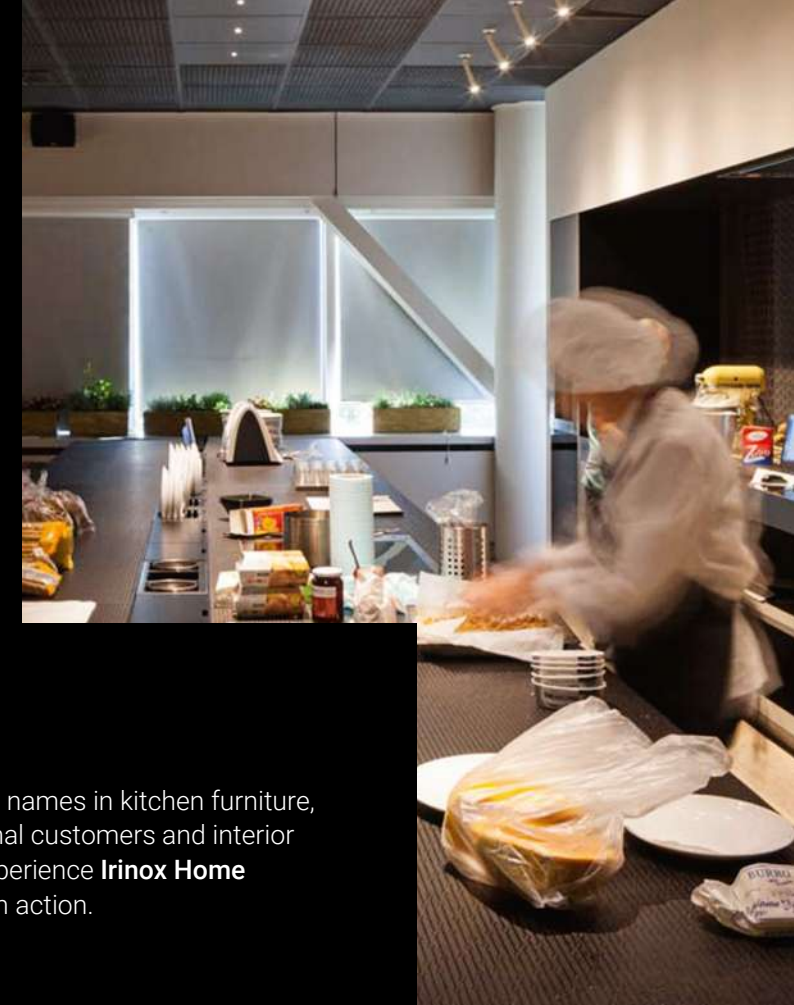

A place where the big names in kitchen furniture, Italian and international customers and interior designers meet to experience **Irinox Home Collection** products in action.





Freddy



Zero



Wave



Vinoteca



Fresco® Élite

Freddy. The multi-function built-in blast chiller



Technical details

➤ Freddy, a professional-standard blast chiller, is designed to fit into all standard 60 cm tall units. It is convenient and practical to fit and is enhanced by an uncluttered design with no protrusions.

Made in AISI 304 18/10 stainless steel, it merges seamlessly with any type of kitchen furniture or décor.

➤ Freddy is available in stainless steel, black glass, mirror glass or any material from the De Castelli range.

➤ Freddy is operated via an easy-to-use digital interface with multiple functions. The controls are soft-touch, entirely without push buttons.

➤ All Freddy components comply with the most stringent international environmental and food safety standards.

Freddy 60 built-in

Min. W. 597 mm
Min. D. 590 mm
Min. H. 595 mm

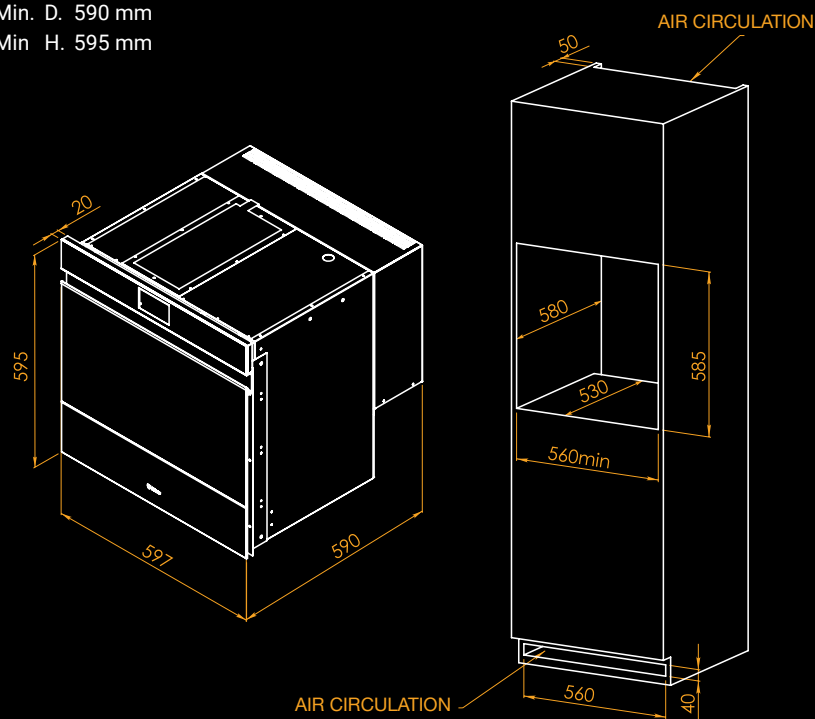

Finishes

All Freddy models can be customized with the following finishes: satin stainless steel, black glass, fronts in a variety of materials and in any colour of the RAL range >> For further details see Available finishes

Technical specifications

| | Freddy 60 | Freddy 45 |
|--|---------------------|---------------------|
| Blast chilling cycle output (+90 °C to +3 °C) | 5,0 kg | 3,5 kg |
| Shock freezing cycle output (+90 °C to -18 °C) | 4,5 kg | 3,0 kg |
| Voltage | 220 - 240 V / 50 Hz | 220 - 240 V / 50 Hz |
| Max. absorbed power | 800 W | 500 W |
| Total current draw | 3.5 A | 2.2 A |
| Compressor power | 0.5 Hp | 0.33 Hp |
| Refrigerant | R290 | R290 |
| Net machine weight | 52 kg | 44 kg |
| Total number of wire shelves | n. 3 | n. 2 |

Standard accessories: Stainless steel wire shelves (2 for Freddy 45, 3 for Freddy 60) / Core probe.

Freddy 45 built-in

Min. W. 597 mm
Min. D. 590 mm
Min. H. 450 mm

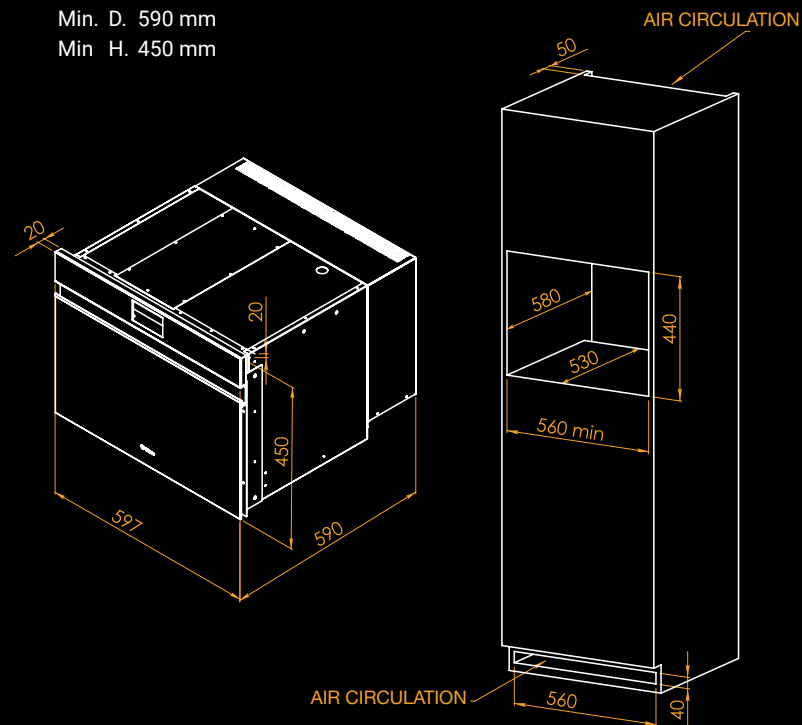

Installation requirements

The appliance comes with a power cord (2 m long). Make sure there is at least 50 mm clearance at the top of the cavity. Fit the appliance away from heat sources, ovens or appliances that produce heat. Provide a Schuko socket behind the appliance.

Optional accessories for Freddy



The first domestic blast chiller

Fresco® Élite. Combi oven/blast chiller



Technical information

- Fresco® Élite can rapidly chill or freeze hot, just-cooked food and thaw it under controlled conditions. It can also cook meat and fish at low temperature, proof bread, pizza and bakery dough, serve you with a piping hot dish whenever you want, preserve food at the ideal temperature and chill wine and drinks.
- Fresco Élite has mechanical door stop with 160° max. opening angle.
- Fresco® Élite is available with door and dashboard in tempered Dark gray glass, handle in brushed stainless steel.

Technical specifications Fresco® Élite

| | |
|--|---------------------|
| Blast chilling cycle output (+90 °C to +3 °C) | 2,5 kg |
| Shock freezing cycle output (+90 °C to -18 °C) | 2,5 kg |
| Voltage | 220 - 240 V / 50 Hz |
| Max. absorbed power | 350 W |
| Total current draw | 2.12 A |
| Refrigerant | R290 |
| Net machine weight | 33 kg |
| Total number of wire shelves | n. 2 |

Standard accessories: one Stainless steel wire shelf.

Fresco® Élite

Min. W. 566 mm
Min. D. 380 mm
Min. H. 382 mm

A multi-function
blast chiller
for the home

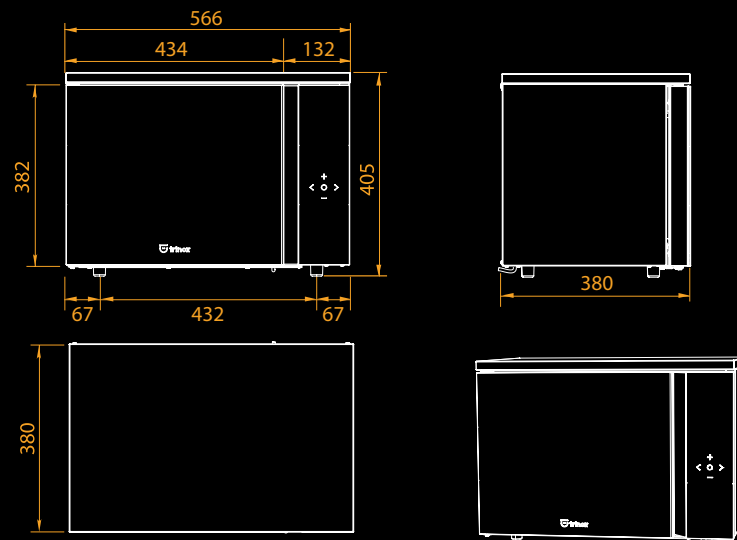

Finishes

Brushed stainless steel outer finish, dark grey toughened glass door, dark grey toughened glass control panel, Brushed stainless steel handle, stainless steel back.



Installation requirements

Make sure there is at least 50 mm clearance at the top of the cavity.
Fit the appliance away from heat sources, ovens or appliances that produce heat. Provide a Schuko socket behind the appliance.

Zero. The vacuum sealer



Technical details

- Available in three heights: 45, 36 or 15 cm.
- Depending on the version, the internal chamber is big enough to contain traditional glass jars. Alternatively, it can be connected to external containers by means of the special adaptor provided.
- Indispensable for vacuum cooking, Zero extends the storage life of food, both solid and liquid, up to fivefold.

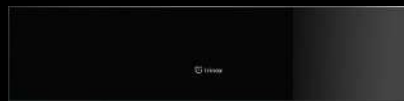

| Technical specifications | Zero 45 | Zero 36 | Zero 15 |
|--------------------------|----------------------------------|----------------------------------|----------------------------------|
| Vacuum pump | 8 m ³ /h | 8 m ³ /h | 3 m ³ /h |
| Voltage | 220 - 240 V / 50 - 60 Hz | 220 - 240 V / 50 - 60 Hz | 220 - 240 V / 50 - 60 Hz |
| Max. absorbed power | 500 W | 500 W | 360 W |
| Max. sealable width | 300 mm | 300 mm | 300 mm |
| Vacuum capacity | 99,9 % | 99,9 % | 99,9 % |
| Residual pressure | < 10 mbar | < 10 mbar | < 10 mbar |
| Chamber in | AISI 304 - 18/10 stainless steel | AISI 304 - 18/10 stainless steel | AISI 304 - 18/10 stainless steel |
| Made of | AISI 304 - 18/10 stainless steel | AISI 304 - 18/10 stainless steel | AISI 304 - 18/10 stainless steel |
| Net machine weight | 48 kg | 45 kg | 36 kg |
| Vacuum chamber volume | 14 litres | 14 litres | 7 litres |

Standard accessories: Set of assorted vacuum bags (25 x 200x250 mm bags, 25 x 250x300 mm bags) ideal for freezing, preserving and cooking food at low temperature / HDPE shelf / External vacuum nozzle / External vacuum connecting pipe.

Zero 45 built-in

Min. W. 597 mm
Min. D. 575 mm
Min. H. 450 mm

Built-in Zero 36

Min. W. 597 mm
Min. D. 576 mm
Min. H. 360 mm

Built-in Zero 15

Min. W. 597 mm
Min. D. 576 mm
Min. H. 140 mm

The built-in vacuum sealer that reaches 99.9% vacuum capacity

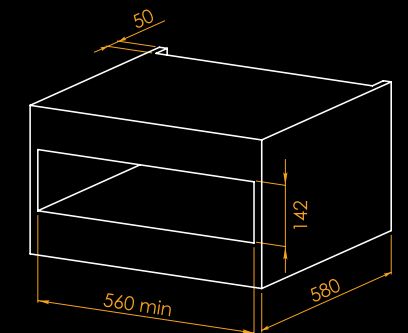
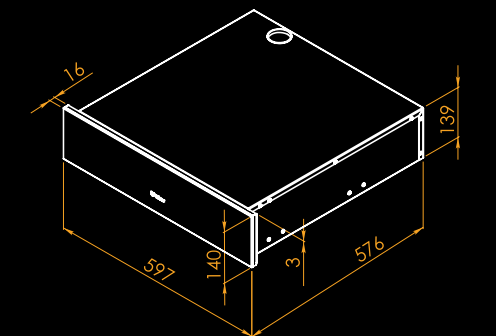
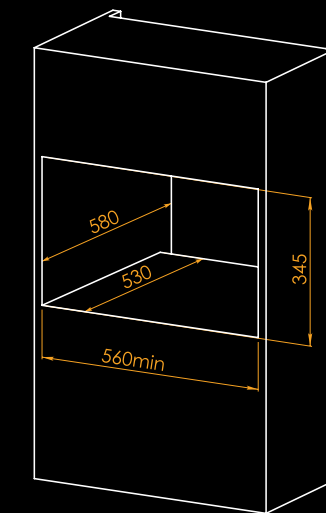
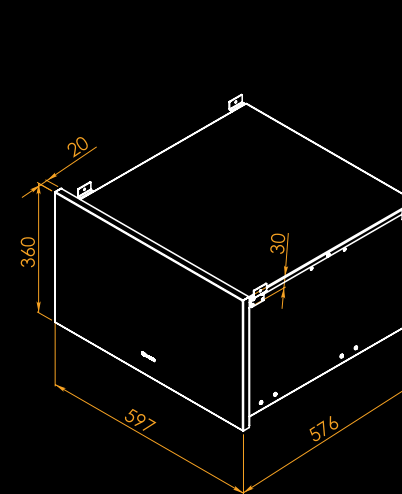
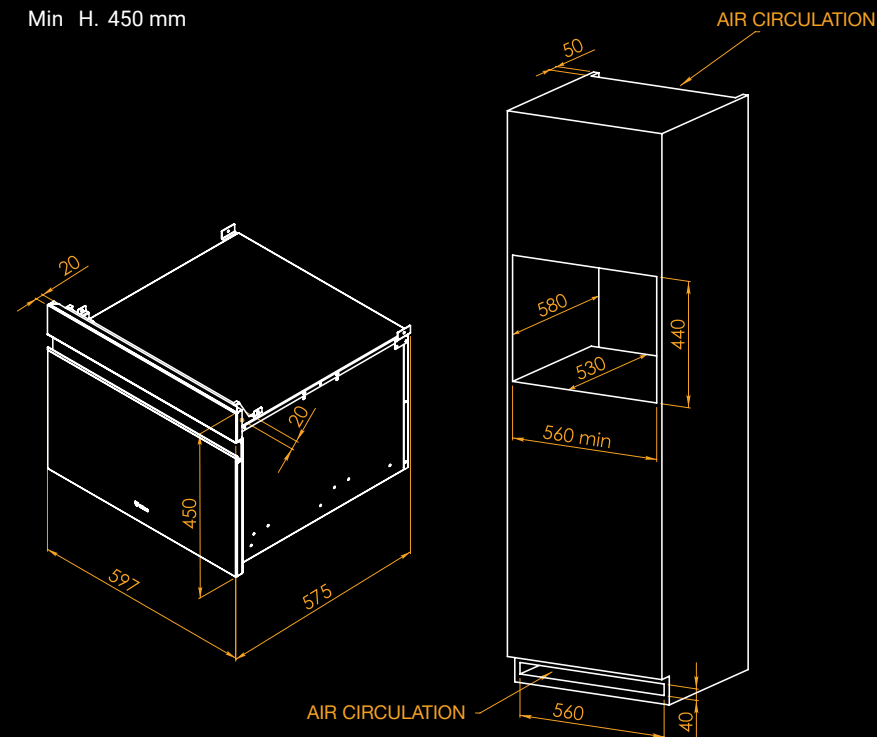

Finishes

All Zero models can be customized with the following finishes: stainless steel, black glass, De Castelli finishes. >> For further details see Available finishes

Installation requirements

The appliance comes with a power cord (1.5 m long). Provide a Schuko plug behind the appliance.

Wave hot&cold. Built-in water dispenser



Technical details

- Wave delivers four types of microfiltered water: room temperature, chilled, chilled carbonated, and hot at 85°C.
- Wave is available built-in, 45 cm high.
- Wave controls are soft-touch technology, totally without buttons.
- Wave comes with a disposable CO2 cylinder (standard) and can also be used with rechargeable cylinder. (An average of 120 litres of carbonated water is produced with a 600 gr. cylinder)
- Inside Wave there is a disposable CO2 cylinder which must be periodically changed. The carbon dioxide consumption depends on the degree of sparkle used for the water.

Built-in Wave Hot&Cold

W min. 597 mm
D min. 547 mm
H min. 450 mm

Any kind of water,
anytime,
at your place.

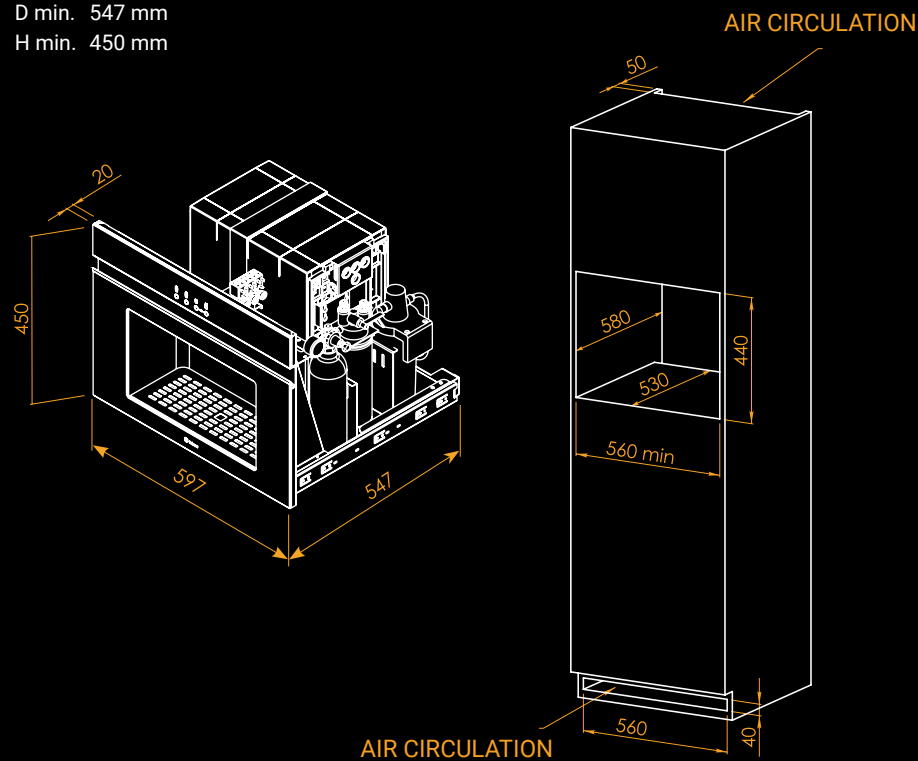

Finishes

All Wave models can be customized with the following finishes: stainless steel, black glass, De Castelli finishes.

Technical specifications

| Technical specifications | Wave 45 Hot&Cold |
|--|-----------------------|
| Compressor Power | 1/11Hp |
| Voltage | 230 V – 50/60 Hz |
| Chilled and sparkling water production | 15 l/h |
| Adjustable carbonation system | min.- max 2 ÷ 3,5 bar |
| Adjustable cold water temperature | da 5 a 12°C |
| Adjustable cold water temperature | 85°C +/- 1°C |
| Water inlet pressure | 2 ÷ 3,5 bar |
| Max. absorbed power | 810 W |
| Capacity of disposable CO2 | 600 g |
| Filter duration | Lt 2.700 / 1 anno |
| Net weight of built-in machine | 35 kg |
| Refrigerant gas | R600 |

Standard accessories: 1 NSF Class 1-certified filter / 8 mm food hose for water connection with 3/4" F. fitting / Anti-flooding device / Water shutoff valve / "claris" hot water filter that preserves against scale formation and ensures durability. The use of the filter is highly recommended when the water (inlet) has a hardness $\geq 17^\circ\text{F}$. The appliance offers a filter "pre-alarm" after 5 months and an alarm after 6 months to check its status, not interrupting the supply. Replacement is recommended between 6 months and 1 year, depending on the water hardness level.

Option: 4kg external CO2 cylinder / Disposable CO2 cylinder.

Installation requirements

The appliance comes with a power cord (1.5 m long) and Schuko plug. A power supply and potable water inlet are required for fitting. A polyethylene food-grade tube is provided, with 3/4" F connector.

For the built-in version on tall units, fit the pull-out runners on the internal side panels of the cabinet. It is essential to leave at least 50 mm clearance at the back of the cabinet from the top to the bottom of the tall unit.

Fit the appliance away from heat sources, ovens or other appliances that produce heat or require the circulation of large amounts of air. Pull the appliance out of its position for periodical maintenance by a specialist technician.

Check the filter and CO2 cylinder regularly. The duration of the filter incorporated in the appliance is 2700 litres or 1 year. The filter must always be in good condition. The appliance offers an 11-month filter pre-alarm and 12-month alarm without interrupting the delivery. The replacement of the filter and sanitization of the plant must be done by qualified persons after 12 months of use to ensure the wholesomeness of the plant and the quality of the water supplied.

Wave houses a disposal CO2 cylinder which must be replaced as and when necessary. The amount of carbon dioxide used depends on the level of sparkle chosen for the water.

On request the system can be prepared for the use of a 4 kg rechargeable external CO2 cylinder with a 3.5 m connecting pipe.

Vinoteca. The wine cooler



Technical details

- Available as a built-in or free-standing version, with glossy black finish and a pedestal plinth.
- Provided with 5 sliding beech wood shelves and a bottom compartment.
- The electronic control panel is situated inside.
- The temperature is shown on the white illuminated electronic display located behind the smoked glass door.
- The interior is illuminated with LEDs that do not produce heat, ensuring that the wine is kept in perfect condition.



Built-in Vinoteca

Min. W. 594 mm
Min. D. 714 mm
Min. H. 574 mm

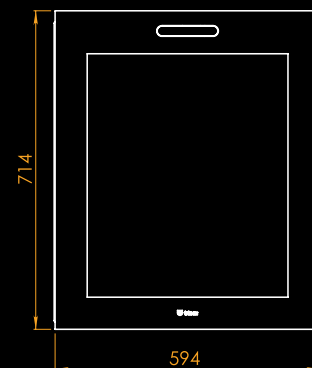
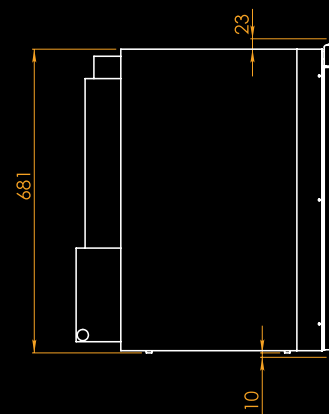
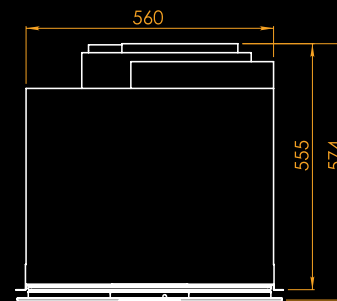

Finishes

Black glass >> for further details see Available finishes

Technical specifications

| Technical specifications | Vinoteca |
|---------------------------|---------------------|
| Power | 65 W |
| Voltage | 220 / 240 V - 50 Hz |
| Max absorbed power | 0,3 A |
| Lamps | 3 W |
| Power consumption | 0,39 kWh / 24 hr |
| Energy efficiency class | G |
| Annual energy consumption | 142 kWh |
| Net machine weight | kg 41 |

Standard accessories: 5 beechwood sliding shelves.

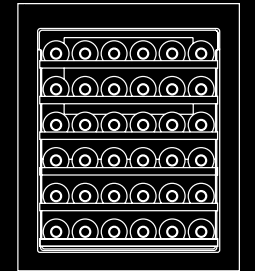

Standard version
36 bottles (100% horizontal)
on 5 wire shelves

Freestanding Vinoteca

Min. W. 608 mm
Min. D. 850 mm
Min. H. 615 mm

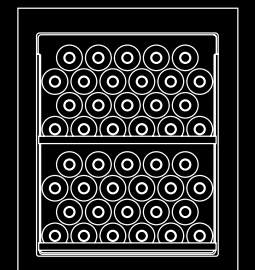
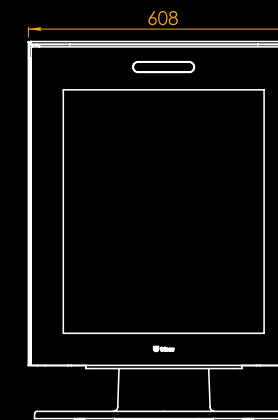
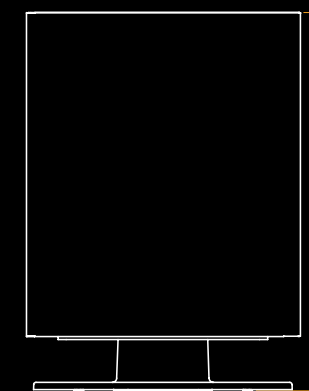
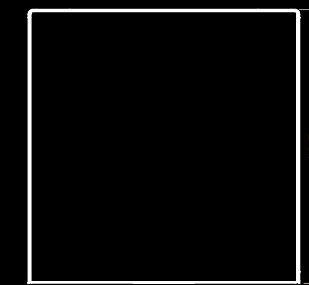

Max. capacity
44 bottles (100% horizontal)
on 1 wire shelf

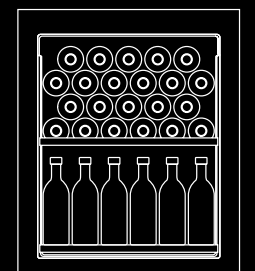

Maximum storage
46 bottles
(48% horizontal and 52%
upright) on 1 wire shelf

Installation requirements

The appliance comes with a power cord (1.30 m long) complete with Schuko plug. Make sure there is at least 50 mm clearance at the back of the built-in cabinet, as shown in the drawing.
Fit the appliance away from heat sources, ovens or appliances that produce heat or humidity.
On delivery stand the appliance upright and wait at least 3 hours before connecting to the power supply.

Vinoteca
is the perfect
storage solution
for your
finest wines.

Available finishes



Satin steel



Black glass



DE CASTELLI finish

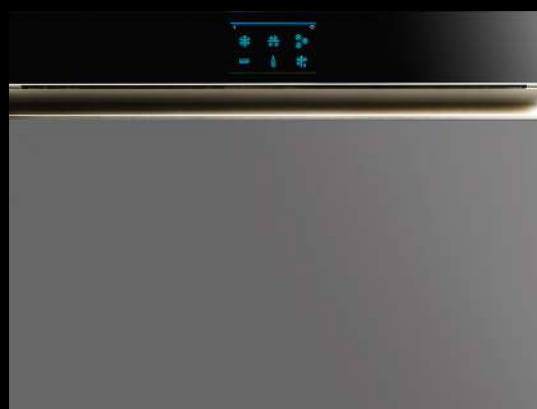

Same finish as customer's kitchen fronts



Mirror glass

All products in the **Irinox Home Collection** are available in stainless steel, black glass or in any material of the De Castelli range.

Freddy and **Zero** are available with a front panel in the same finish as the customer's kitchen fronts and in any colour of the RAL range. **Vinoteca** is only available in the black glass finish.

DE CASTELLI



- Striped Délabré brass
- Délabré brass

- Striped Délabré iron
- Délabré iron

- Striped Délabré copper
- Délabré copper

Customizable front panel

Freddy 60

W 597 - 0.5 mm
H 470.7 - 0.5 mm
D 4 ± 0.1 mm
Weight min 1.7 kg / max 2.8 kg

Freddy 45

W 597 - 0.5 mm
H 470.7 - 0.5 mm
D 4 ± 0.1 mm
Weight min 1.7 kg / max 2.8 kg

Zero 45

W 597 - 0.3 mm x H 326.7 - 0.2 mm
D 4 ± 0.1 mm
Weight min 1.2 kg / max 2.0 kg

Zero 36

W 597 - 0.5 mm x H 358 - 0.3 mm
D 4 ± 0.1 mm
Weight min 1 kg / max 2 kg

Zero 15

W 597 - 0.5 mm x H 140 - 0.3 mm
D 4 ± 0.1 mm
Weight min 0.5 kg / max 1 kg

concept
and art direction
claim.brandindustry

photography
Alessandro Bon
Sabrina Scichitano

lithography
cruzlab.com

special thanks
Copat Life S.r.l.

Irinox Home
Via Madonna di Loreto 6/B
31020 Corbanese (TV) / Italy
+39 0438 5844
www.irinoxhome.com
info@irinoxhome.com



www.irinoxhome.com