

 irinox



The new
experience
of freshness



The new
experience
of freshness



Pioneer. Visionary. Trendsetter. Since 1989.

Irinnox is **The Freshness Company**, where everything takes place respecting the freshness and quality of food. Continuous innovation, the steadfast commitment to producing durable and high-performing products, uncompromisingly choosing the best materials have been our guiding values since the very beginning.

We believe that the future requires attention, responsibility and care: only in this way is it possible to promote an increasingly sustainable lifestyle. Thanks to Irinnox Home Collection, we significantly reduce food waste, contributing to the protection of the planet. A concrete gesture, every day.

Our roots are set in a region that values quality and the natural and cultural resources that surround us: a heritage that we continue to honour with passion.

With Irinnox Home Collection, the kitchen turns into a space devoted to health and well-being.

Our story:
from professional
excellence
to your kitchen.

1989

Irinnox is born, with the first professional blast chillers for confectionery and catering.

2002

Innovation enters the home. Freddy, the first household blast chiller in the world, is born.

2005

From vision to reality: Irinnox Home Collection, a range of innovative household appliances, sees the light.

2011

Fresco®, the first freestanding compact blast chiller, is born.

2025

The evolution continues. Freddy is enriched with new features, becomes more simple and more user-friendly.

Innovation. Style. Design.

IRINOX HOME COLLECTION



Freddy | p. 8

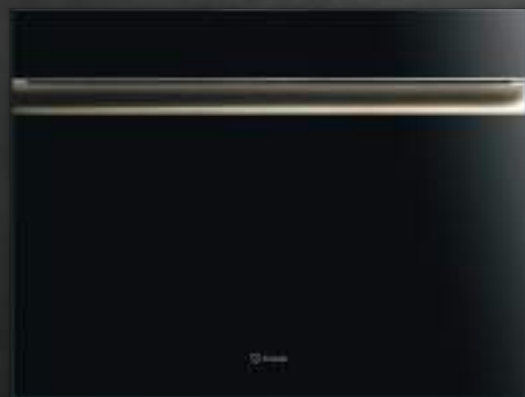

Zero | p. 50



Fresco® Élite | p. 46

Irinox Home Collection translates the potential of professional technology into elegant and user-friendly appliances, designed to perfectly complement every kitchen. It becomes your daily ally, capable of changing the duration of time: it preserves the authenticity of ingredients, respects personal rhythms and opens up endless creative possibilities. The kitchen turns into a space for health and well-being, where freshness does not know any seasons, and every preparation reaches the top of its expression.



Wave Hot & Cold | p. 54



Vinoteca | p. 58

Freddy built-in multifunction blast chiller

Fresco® Élite countertop multifunction blast chiller

Zero Vacuum sealer

Wave Hot&Cold Water dispenser

Vinoteca Wine cabinet



Change the way you think about the seasons.

In an age where everything accelerates, Irinox Home has perfected the art of stopping what really matters: the authentic essence and intact taste of ingredients, collected at the best time. For the pleasure of freshness that defies the calendar. Through innovation and functional design, it has brought into the home kitchen a new dimension of time, entering into a dynamic relationship with it. Irinox Home Collection is evolution in technology and design to protect a wealth within everyone's reach: the vitamins, colours, tastes and smells of fresh food.



Freddy 60

BUILT-IN MULTIFUNCTION
BLAST CHILLER

FREDDY

IRINOX HOME COLLECTION



Freddy, capture the moment.

Real creativity in the kitchen is choosing when. Freddy lets you go back to the exact moment when the ingredients are fresh, the dishes are just cooked, the temperature is ideal.

It safeguards the essence of vitamins, colours and aromas until the perfect occasion. Seasonality becomes a fluid concept, without boundaries. The blast chilling technology is as gentle as a caress, enhancing the properties of each foodstuff – yet it is so fast that it stops bacterial growth.

The blast chiller is an invaluable ally, capable of tripling the shelf life of raw or cooked foods, transforming each dish into a sensorial experience that transcends the limits of time.

For those who seek the authentic and unmistakable taste of freshness, always.



Freddy 45, made to suit your space.

Same features, compact size.

Keep nutritional properties intact, preserve the quality of authentic flavours, prepare food beforehand, surprise friends at the last minute.

Freddy is designed to fit into any modern modular kitchen. Its compact size makes it perfect to suit the spaces of your home.



Freshness knows no seasons.

BUILT-IN MULTIFUNCTION
BLAST CHILLER
FREESTANDING

FREDDY
FRESCO®
ÉLITE

With Irinox, enter the history of innovation and embark on a journey that will transform your relationship with food forever. An experience whose advantages let you discover a new way of preserving, preparing and savouring food.

IRINOX HOME COLLECTION



Zero waste

With Irinox Home's technology, you will triple the shelf life of food, dramatically reduce waste and enhance each ingredient.



Extended freshness

The freshness of all food, either raw or cooked, is retained perfectly. Nutritional properties, colours and textures remain perfect, even after some time. Healthy eating becomes a daily habit.



Limitless seasonality

Enjoy seasonal produce at any time. Capture the best of each season and enjoy it when you want, respecting the rhythms of nature but overcoming its time limits.



Superior quality

Rediscover the real taste of food, even after preserving it, ensuring lasting quality for your dishes. For an outcome that always lives up to the highest expectations.



Buy, cook, eat when you want

Unleash your creative streak when inspiration strikes, organise meals in advance according to your rhythms or needs, without sacrificing freshness and flavour when you bring them to the table.



Chef-worthy results

The tastiest recipes and the great chefs' cuisine on your table. Blast chilling and low-temperature cooking are two techniques that can be combined to achieve exceptional results in the kitchen. The Irinox Home technology combines these technologies for tender, tasty food that can be preserved for a long time.



Healthier cuisine

Explore new possibilities: not just blast chilling, but also controlled leavening, low-temperature cooking and much more, for an experience spanning tradition and technology. When you prep food at home, you have control over the ingredients and processes, making your dishes more wholesome and healthier, for you and your whole family.



More time for you

Take back the time to devote to what you love. Rediscover the pleasure of sharing meals by prepping in advance. Enjoy your time, always without foregoing quality.



-35 °C
blast chilling

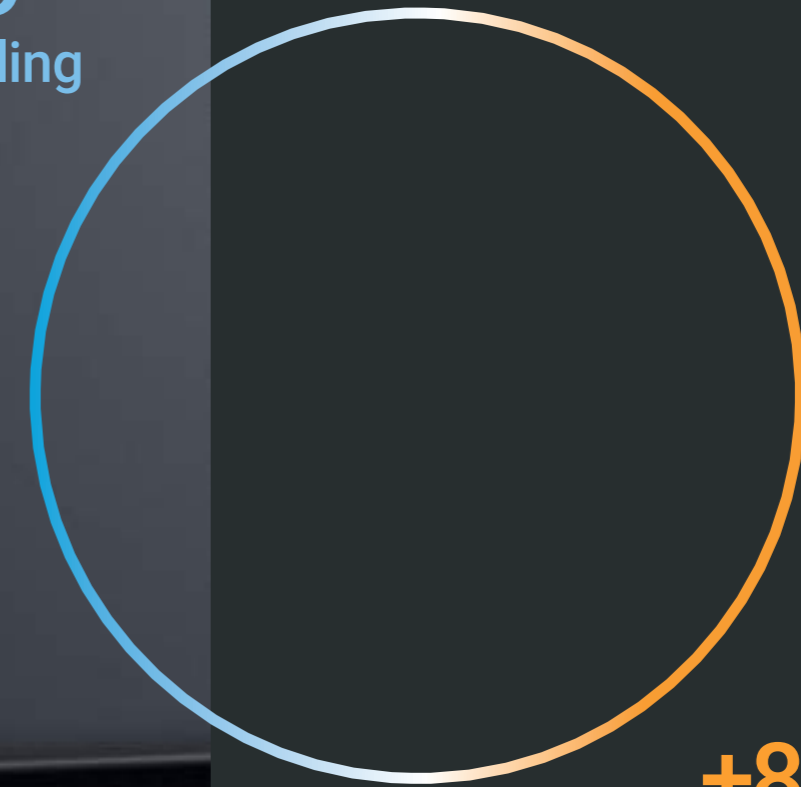

+80 °C
slow heating

An easy,
user-friendly,
engaging display.

The software was designed to enhance every dish, every ingredient, enabling users to express their creativity to the fullest.

A user-friendly technology that respects the nature of every foodstuff. Over 30 functions, all in one simple touch. With stylised icons, a multi-language display and immediate visual pathways, the software straightforwardly guides users through all functions, including the most advanced ones.

You can select directly the desired food or explore the cold, hot functions, or the special preset ones, to make the most of Freddy's extraordinary potential. In one instant, with just one touch.



COLD FUNCTIONS

BUILT-IN MULTIFUNCTION
BLAST CHILLER

FREDDY

Cold is the ally of quality on the table.

Cold has the ability to enhance the natural quality of foods, preserving their essence. The various functions, designed to extend time according to the preparations (freshly cooked, fresh, or particularly delicate foods), let you explore the many possibilities that transform the journey spanning technology and nature into a celebration of flavours, colours and nutrients.



Blast chilling



Cold freezing



Hot freezing



Thawing



Personalized storage





Prolonging
authentic
flavour.

The ability
to seize
the moment.

IRINOX HOME COLLECTION



 **Blast chilling**

To rapidly lower the core temperature of hot and freshly cooked food down to +3 °C. In this way, it ensures the quality, flavour, colours and aromas of food, tripling their shelf life.

To store any cooked food in the fridge up to 7 days.

 **Hot freezing**

This cycle lowers the temperature to +3 °C and then gradually drops to -18 °C: the result is rapid but non-aggressive freezing, ideal for hot or particularly delicate foods.

An indispensable function for the most delicate foods that must be stored in the freezer up to 6-8 months.



That moment
of eternal
freshness.

Anticipation
savoured
now.

IRINOX HOME COLLECTION



 **Cold freezing**

Blast chilling makes it possible to leave the natural goodness of food unaltered, even storing it in the freezer for over 6 months, preserving flavour, texture and nutritional properties. When consumed, you will enjoy the same original freshness and quality, as if time had never passed.

For preserving in the freezer up to 6-8 months.

 **Personalized storage**

Proper preservation is the secret to maintaining intact the quality of food. Specific temperatures, which are hardly reached in a household freezer or refrigerator, are essential to preserve authentic textures and flavours, even the most delicate, over time. This feature makes it possible to store any food at its ideal temperature, respecting its nature: from the freshness of a perfect tartare at 0 °C to the irresistible creaminess of artisanal ice-cream at -12 °C.

To preserve even the most delicate food at the perfect temperature before serving it.



HOT FUNCTIONS

BUILT-IN MULTIFUNCTION
BLAST CHILLER

FREDDY

Heat, the versatile star of transformation.

Heat reveals the potential of preparations through Freddy's many functions.

Technology allows natural flavours to be enhanced, respecting the identity of the individual ingredients: from slow cooking that preserves juices and aromas, to the convenience of the ready-made dish that optimises time, up to controlled leavening that ensures impeccable results for bread and doughs.

Precision and versatility combine to elevate every daily preparation.



Low temperature
cooking



Ready dish



Proofing



Personalized
storage





The calm
that intensifies
flavours.

Synchronised
with your
time.

IRINOX HOME COLLECTION



Low temperature cooking

Slow, even cooking enhances meat and fish. This method makes it possible to preserve the natural succulence of foodstuffs, enhancing the complexity of their flavours and ensuring softness that melts in the mouth.

To cook meat and fish gently, enhancing their flavour.



Ready dish

The pleasure of coming back home and finding a hot and steaming dish, as if just cooked. This feature makes it possible to store your favourite food at the ideal temperature, as if it were in the fridge, and then to take it to the right temperature for eating at the scheduled time, without affecting texture or flavour.

So that when you get back home you can find the warmth and aroma of a dish ready to be enjoyed.



HOT FUNCTIONS

When it is all a matter of degrees.

IRINOX HOME COLLECTION



BUILT-IN MULTIFUNCTION BLAST CHILLER

FREDDY



Proofing

Controlled leavening at a constant temperature allows the yeast contained in bread, pizza, and brioche to work its magic. Freddy ensures all leavened products have an intense flavour, a light structure, the right crumbliness and, above all, better digestibility.

For more digestible dough of bread, pizza and brioche.



SPECIAL FUNCTIONS

BUILT-IN MULTIFUNCTION
BLAST CHILLER

FREDDY

The magic in the everyday.

Freddy's special preset cycles make it possible to obtain new preparations, from the most refined to the most useful for new lifestyles.



Raw fish sanitization

To enjoy raw fish in utter safety.



Marination

To marinate meat and fish quickly.



Cooling drinks

To quickly cool any drink in a matter of minutes.



Chafing dish

To warm up food inside any type of container.



Ice cream

To enjoy ice cream at the ideal temperature and texture or to store it in the freezer for a long time with no alterations.



Cryo/Beauty

To chill and increase the effectiveness of beauty products.



Grocery

To extend the shelf life of your shopping in the fridge.



Drying

To dry fruit, vegetables, meat, fish at controlled temperature.



Yoghurt

To prepare creamy and natural yoghurt at home.



Baby

To plan, preserve and regenerate your baby's food.



Chocolate melting

To melt chocolate evenly, reaching the perfect consistency.



Ice lollies

To prepare delicious ice lollies fast, with ingredients selected by you.



Ice

To quickly obtain ice cubes with a crystal-pure appearance.





The safe
flavour of the sea.

Pleasure
must be savoured
at the right
point.

IRINOX HOME COLLECTION



 **Raw fish
sanitization**

The safety of eating raw fish without any worries: this function destroys microorganisms and parasites that are potentially harmful to your health. A convenient and effective method that protects the quality of fish and respects its freshness, texture, and authentic taste.

**To enjoy raw fish
in utter safety.**

 **Cooling
drinks**

It only takes a few minutes to chill wine and beverages, and be able to offer refreshing aperitifs to your guests. Freddy chills bottles at a speed of approximately -1 °C per minute, ensuring the pleasure of enjoying drinks at the ideal temperature.

**To be always ready when
unexpected guests
arrive.**



The secret
of perfect
preparations.

Pure
crystals.

IRINOX HOME COLLECTION



Yoghurt

Constant temperature control is the secret to obtaining delicious, velvety yoghurt, made at home with simple and natural ingredients, with no preservatives or additives. From traditional recipes to plant-based alternatives, such as almond or soy, every variant is creamy and wholesome, to meet every dietary preference.

To make creamy and natural yoghurt at home.



Ice

Make pure, solid and compact ice cubes in minutes, with flawless transparency. They are the perfect complement to cool aperitifs and any other beverage with style.

To serve your favourite cocktails with the addition of crystalline ice.



SPECIAL FUNCTIONS

Freshness ready for use.

IRINOX HOME COLLECTION



Grocery

Quickly bring the food you have just purchased back to the optimal temperature, to keep it fresh longer and extend its shelf life. Particularly useful to protect fruit, vegetables, cold cuts, meat, fish and dairy that got unavoidably warmer on the way home from the supermarket from thermal stress.

To extend the shelf life of your shopping in the fridge.

BUILT-IN MULTIFUNCTION BLAST CHILLER

FREDDY





FOOD FUNCTIONS

BUILT-IN MULTIFUNCTION
BLAST CHILLER

FREDDY

Even easier, even more intuitive.

The right cycles for every type of food.

To make the technology even more user-friendly, through a guided pathway, with preset timing and temperature.



Meat

To preserve and enhance the taste of every cut of meat.



Pasta / Rice

To prepare the weekly meals beforehand or to preserve them, so they are always ready.



Fish

To enhance fish, no matter how it is served: raw, cooked at low temperature, marinated.



Bread / Pizza

To obtain perfect leavened goods and have them soft and smelling delicious, even after some time.



Vegetables

To capture the freshness of vegetables and preserve it intact over time.



Desserts

To make desserts like a real professional, optimising the timing and ensuring always flawless results.



Soups / Sauces

To chill or freeze liquid preparations and preserve them in the fridge or freezer, even in single portions.





The second course
takes the floor.

Preserving
the flavour
of colours.

IRINOX HOME COLLECTION

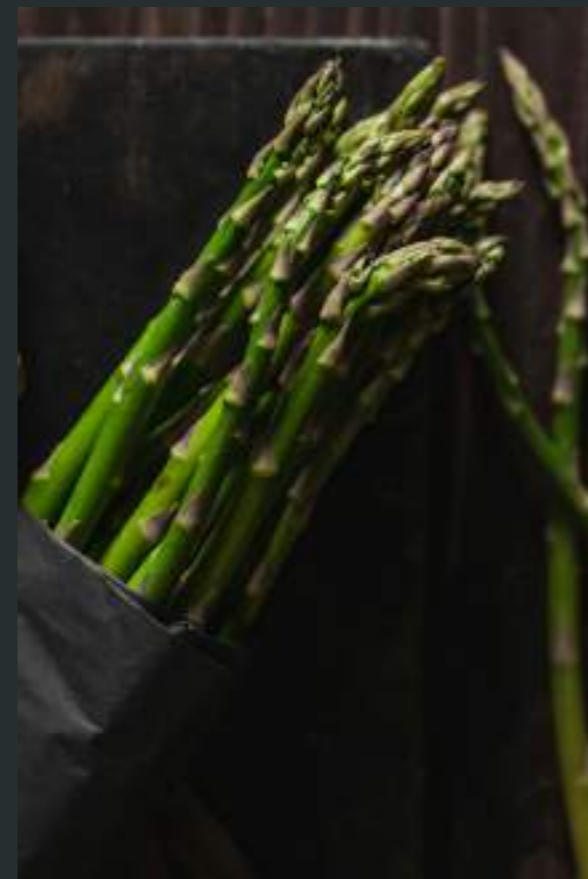

Meat

Endless possibilities that enhance every cut of meat. From prolonged preservation, thanks to cooling and freezing, to slow and soft cooking, to the heightening of flavours with marinades.

**To enhance meat
in all its versatile
preparations.**



Vegetables

Optimise the preservation of vegetables. This function exploits the benefits of blast chilling and freezing to maintain the bright colours, the vitamins and the crunchiness of vegetables. It respects the quality and organoleptic properties of vegetables and preserves their freshness over time.

**To enjoy the authentic
flavour of fresh
vegetables at any time.**



Family recipes,
as if just
made.



Soups Sauces

Quickly chill or freeze soups and sauces, even boiling hot, to preserve them for longer. Suitable for large quantities as well as for convenient single portions. Convenience and quality meet to ensure speed and safety with freer time management in the kitchen.

To chill or freeze liquid preparations, even if boiling hot.

The culture
of leavening.

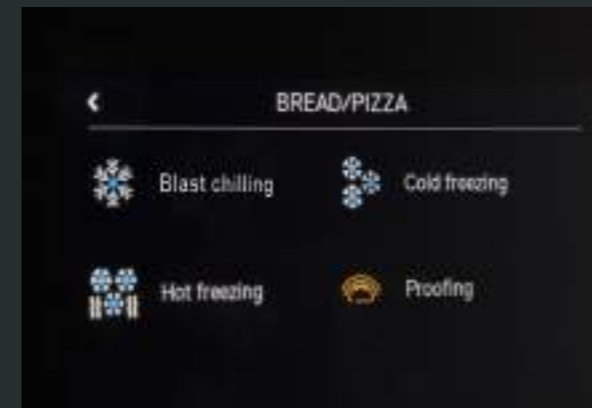

Bread / Pizza

The perfection of leavened goods at your fingertips. It lets you precisely manage every step, from leavening to immediate chilling when necessary. Lastly, freezing preserves the structure and consistency of any type of dough over time, to enhance its authentic flavour.

To rediscover the delectable aroma of homemade bread and pizza, as if just out of the oven.



Timeless delights.



Desserts

The secret of perfect desserts is controlled management of leavening, calibrated with precise chilling that stabilises the preparation, all the way to freezing to preserve structure and softness. Furthermore, it also simplifies the critical unmoulding operation, making it easy to detach cakes from moulds, for impeccable presentations.

For flawless cakes with fine pastry shop quality.



FREESTANDING MULTIFUNCTION
BLAST CHILLER | FRESCO®
ÉLITE

Fresco® Élite



IRINOX HOME COLLECTION

Fresco® Élite, the technology that transforms your habits.

Fresco® Élite is the blast chiller that redefines your routine and your relationship with the time you spend in the kitchen. With its elegant design, it perfectly blends into your daily needs.

Fresco® Élite goes beyond mere functionality. It carefully preserves the essence of every ingredient: the authentic freshness, the intense flavours, the perfect consistency and the whole nutritional value.

Fresco® Élite is a new way of experiencing contemporary cuisine, respecting your time needs and enhancing your preparations.

Its distinctive design is eye-catching, but what makes it truly indispensable is the user experience.



Blast chilling

To store any cooked food in the fridge up to 7 days.



Shock freezing

For perfectly preserving in the freezer up to 6-8 months.



Delicate freezing

For the most sensitive food that is stored in the freezer.



Controlled thawing

For soft thawing, that does not spoil food.



Beverage cooling

To be always ready when unexpected guests arrive.



Customised preservation

For the preservation of special food (-20 °C / +65 °C).



Low temperature slow cooking

To cook meat and fish gently enhancing their flavour.



Leavening

For more digestible bread, pizza, brioche and focaccia dough.



Ready-made dish

To find a hot dish when you come back home.

Zero 45

IRIN HOME COLLECTION



Zero, the hood vacuum sealer that preserves essence.

Zero is the first built-in hood vacuum sealer, derived from professional appliances, that is able to reach up to **99.9%** vacuum, to increase up to 5 times the shelf life of food.

Its control panel with soft-touch technology offers a user-friendly experience with **three levels of vacuum** and specialised cycles for **marinade, dry-ageing and liquids**. Zero flexibly adapts to different needs, even the most advanced, letting you create customised setups that respect the nature of every ingredient and the desired result.

Zero is equipped with a steel tank with a capacious sealing bar, that holds large bags.

With Zero it is also possible to prepare food for sousvide cooking in water, in Freddy or in steam oven. Its professional built-in technology reaches a vacuum level close to absolute zero, sealing the organoleptic properties and creating a dimension where every authentic flavour is preserved over time.

Zero is available in three models: Zero 45, Zero 36 and Zero 15.



•••

Light vacuum

To hermetically seal crush-sensitive food, such as soft cheese, sweets, salads.

•••

Storage vacuum

For vacuum sealing most foods.

•••

Extreme vacuum

To vacuum pack food such as raw vegetables and cold cuts or prep for sous-vide cooking.



Dry ageing

To soften meat, which can even undergo several vacuum cycles.



Marinade

To enhance the flavour of food with oil and spices in 5-10 minutes instead of hours.



Liquids

To seal bags containing cold liquid products, such as soups, sauces, ragout, jam or baby food.

Wave Hot&Cold 45

BUILT-IN WATER DISPENSER | WAVE HOT&COLD

IRINOX HOME COLLECTION





Wave Hot&Cold, to each their own style.

Wave Hot&Cold is the household water dispenser which is connected directly to the local water mains and dispenses high-quality, **hot or cold still or sparkling water**, microfiltered from the first to the last drop.

Purity guaranteed by the special filter, capable of removing up to 99.9% of impurities with a diameter up to 0.5 micron, including asbestos fibre and other microorganisms in water, chlorine and algae.

Wave Hot&Cold is not just purity: it improves the taste of water and ensures every sip is naturally fresh.

The four flavours of purity
Wave Hot&Cold dispenses 4 types of microfiltered water:



Water at room temperature



Cold microfiltered water



Cold sparkling water



Hot water at 85 °C



Vinoteca 60

IRINOX HOME COLLECTION



Vinoteca 60 dual-temperature, where everything is under control.

The Irinox Home 60 wine cabinet is designed for true connoisseurs who love precisely controlling the ideal environment for each bottle.

Indeed, its dual temperature zone makes it possible to respect the features of both white and red wines.

The elegant "full glass" door with push open system protects the bottles from UV rays, combining aesthetics and functionality, while the LEDs in three customisable colours (orange, white, blue) create the suitable atmosphere, balancing light and shadows.

The oak wood supports offer great versatility: when properly set up, they can accommodate bottles other than the classic Bordeaux ones. An innovative feature is the option to also accommodate magnum size bottles, an essential detail for those who love collecting important bottles, because special occasions deserve the right space.

For exceptional performance with a touch of elegance.



irinox



Vinoteca 45





Vinoteca 45 single- temperature

The 45 wine cabinet holds all the technological excellence of the larger model in a more compact size.

With a single temperature zone, adjustable from 5 °C to 20 °C, it lets you create an environment suitable for refined whites or full-bodied reds.

Furthermore, the elegant "full glass" door protects the bottles from UV rays.

Vinoteca 45 offers the following finishes and features:

- Second-generation push-open system.
- "Full glass" door.
- LED lights in three colours to choose from (orange, white, blue).
- "Hettich" hinges, also available in black.
- Adjustable oak supports, to hold bottle sizes other than Bordeaux.

Vinoteca 15 single- temperature

Vinoteca 15 can be set in a column or under a top to perfectly complement any kitchen layout.

Vinoteca 15 has a single temperature zone, adjustable from 5 °C to 20 °C via a touchpad digital display. It ensures optimal conditions thanks to dynamic compressor cooling which evenly distributes temperature and moisture.



The creative freedom
of a designer emerges
with **Irinox Home**
solutions.



Transforming the concept of kitchen into a space that reflects the unique identity of those who use it becomes an exploration of choice, taste, personality. Compositional modularity offers architects and designers a series of diversified functional elements to meet all the practical and aesthetic needs of every design challenge, and to turn desires into spaces capable of inspiring.

Composition ideas to combine aesthetics and functionality.

Innovation, design and technology combine into one word: experience.

Irinox Home creates solutions capable of simplifying daily life. It offers a series of versatile and modular combinations based on different needs, to inspire a new way of experiencing time in the kitchen, and prolonging freshness.

Perfect Combo

Freddy 45 / Zero 15 / Oven 60

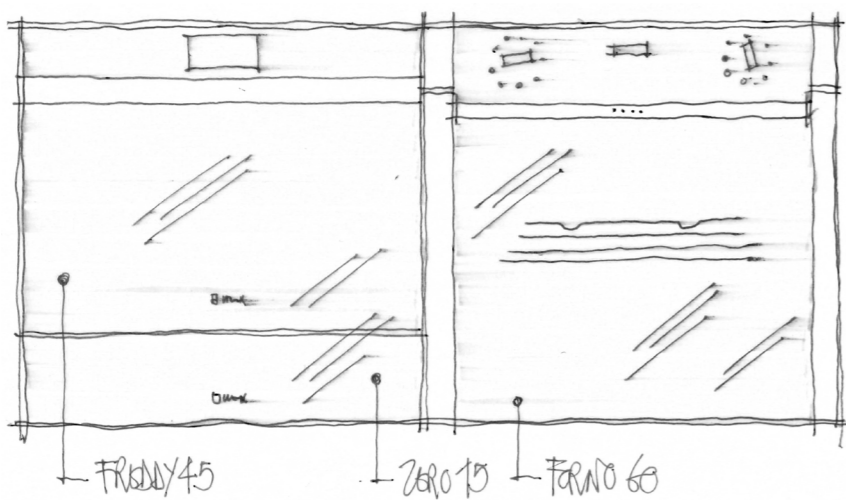

Duo Gourmet

Freddy 60 / Oven 60

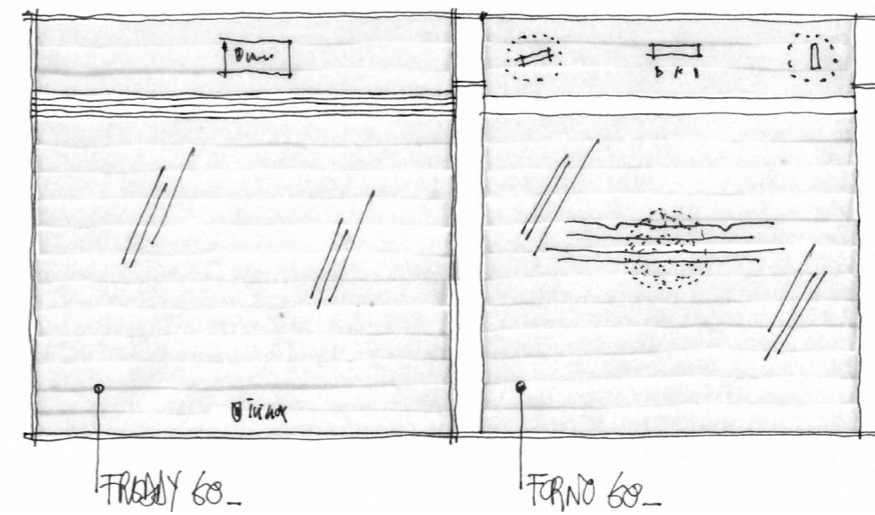

The Kitchen Hub

Wave Hot&Cold 45 / Freddy 45 / Oven 45

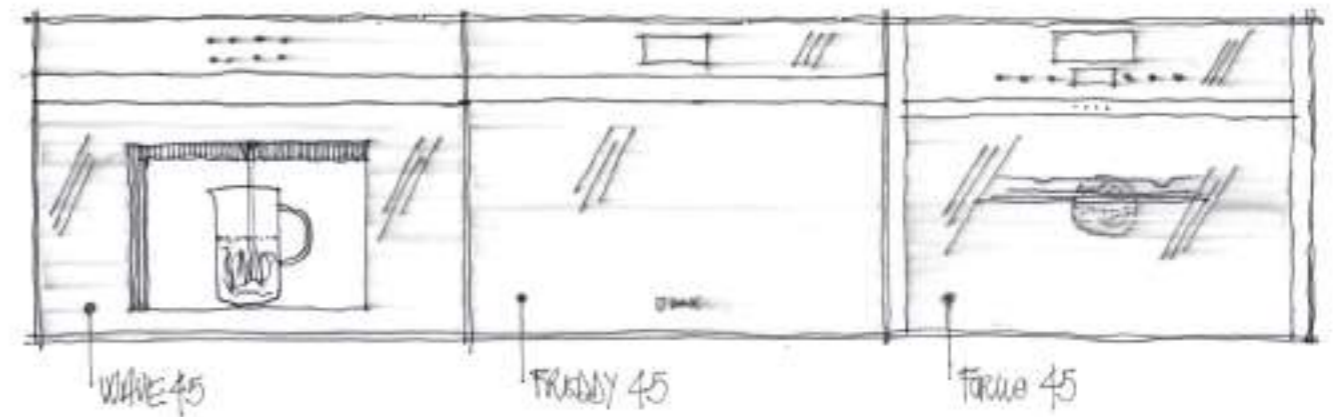

Trio Chef

Freddy 45 / Oven 45 / Zero 45

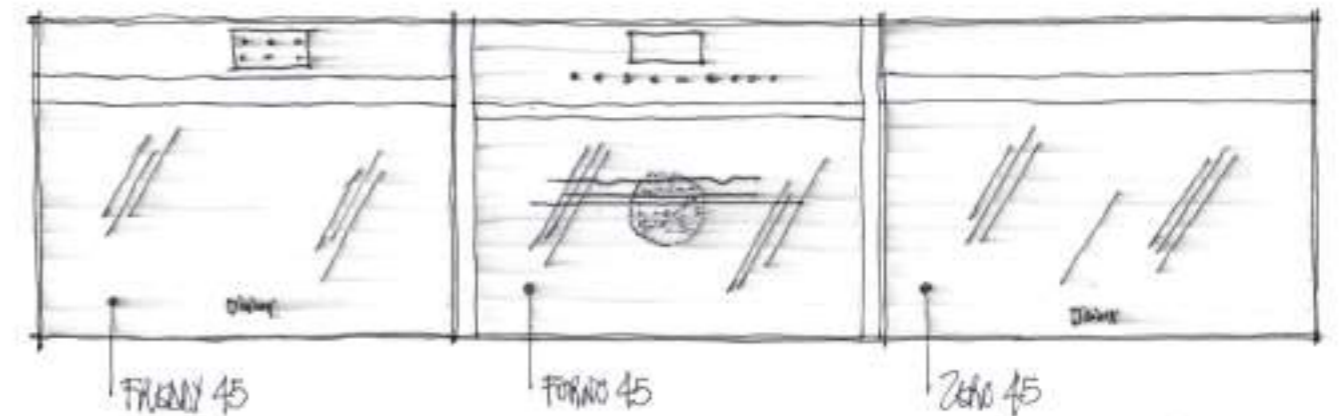

Fresh Pleasure

Freddy 60 / Wave Hot&Cold 45 / Vinoteca 15

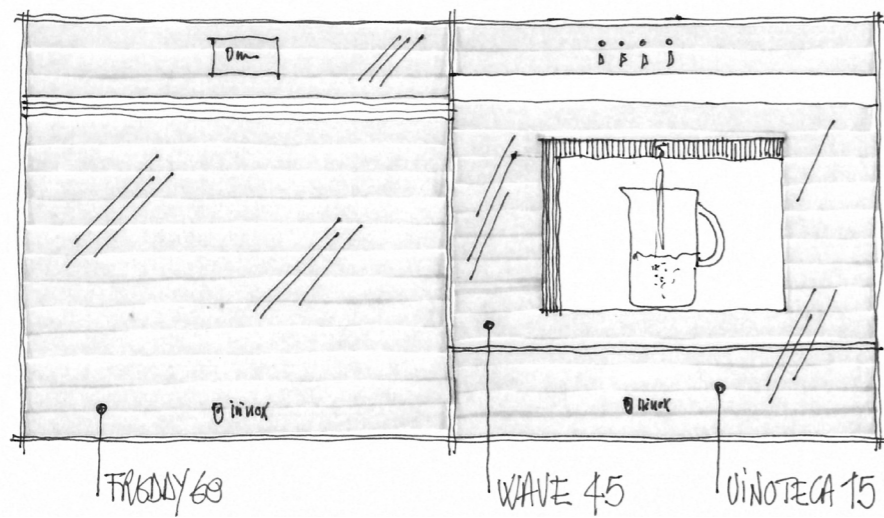

Wine & Water Lifestyle

Vinoteca 45 / Wave Hot&Cold 45

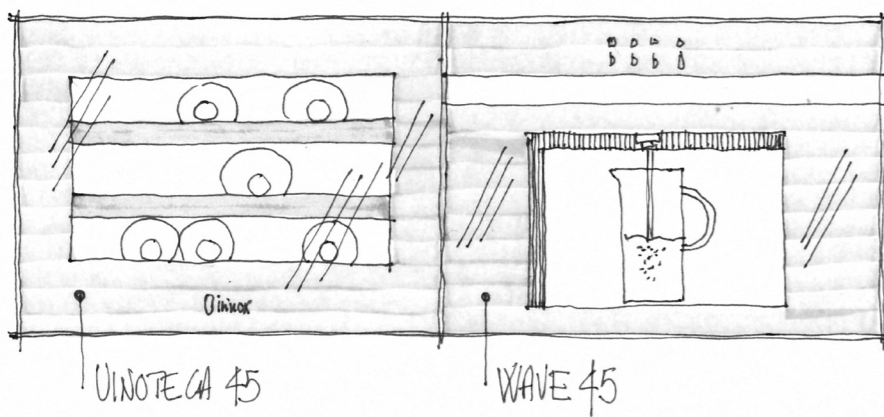

Home Comforts

Freddy 45 / Vinoteca 45

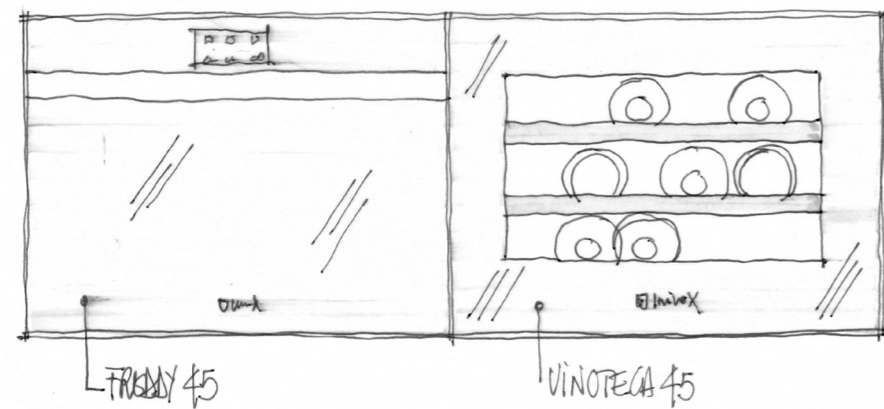

Drink Atelier

Wave Hot&Cold 45 / Vacuum drawer 15 / Vinoteca 60

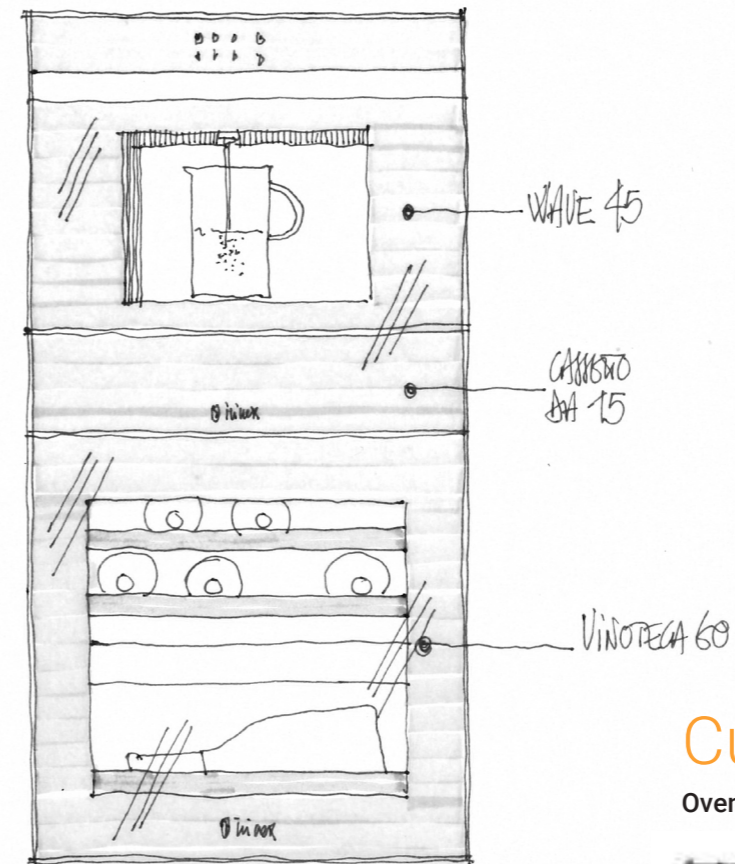

Culinary Wall

Oven 60 / Freddy 60

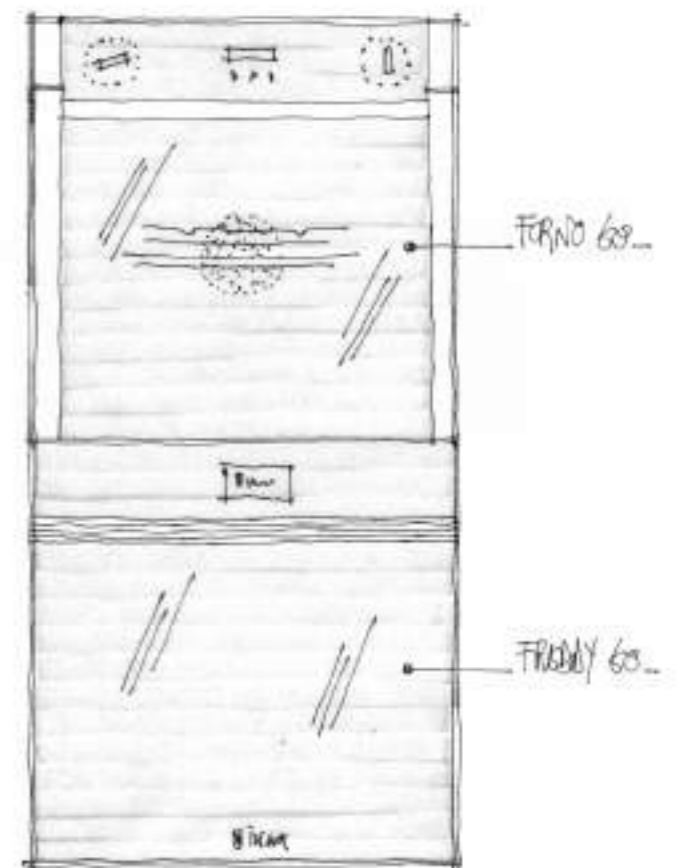

Freddy

The first household blast chiller since 2002.

Built-in multifunction blast chiller.

Freddy, chiller derived from professional appliances, is designed to fit into all standard 60 cm columns. It fits perfectly thanks to an essential design, completely without protruding parts that allows it to match any kind of kitchen or room. Freddy is available in brushed steel, black glass and De Castelli material. Freddy is operated via a digital interface, simple to use and with full features. The controls have soft-touch technology, without any buttons. All Freddy's components comply with the strictest international standards regarding environmental, health and food safety.

TECHNICAL SPECIFICATIONS	Freddy 60	Freddy 45
Blast chilling cycle yield (from +90 °C to +3 °C)	5,0 kg	3,5 kg
Shock freezing cycle yield (from +90 °C to -18 °C)	4,5 kg	3,0 kg
Voltage	220 - 240 V / 50 Hz	220 - 240 V / 50 Hz
Max absorbed power	870 W	500 W
Total absorption	3.8 A	2.2 A
Compressor power	0.57 Hp	0.33 Hp
Refrigerant gas	R290	R290
Net machine weight	56 kg	43 kg
Grille capacity	3	2

Standard equipment: Stainless steel grilles (2 for Freddy 45, 3 for Freddy 60) / Core probe.

Assembly precautions

The household appliance has a connection cable (length 2 m). **Make sure to leave an air gap of at least 80 mm at the top of the recess and in the plinth.** It is recommended to install the appliance away from heat sources, ovens or other appliances that produce heat. Provide for the Schuko plug behind the appliance.

Finishes

It is possible to customise the finish of all Freddy models: brushed steel, black glass and De Castelli. Furthermore, they are available with the kitchen door finish required by the customer and in RAL colours. (See page 84)

Accessories

Stainless steel lid
325 x 265 mm

Polycarbonate lid
325 x 265 mm

Grille

Stainless steel pan
325 x 265 x h 40 mm

Stainless steel pizza pan
325 x 265 mm

Polycarbonate pan
325 x 265 x h 65 mm



Built-in Freddy 60



L 595 mm
D 600 mm
H 595 mm
Capacity: 56 Litres

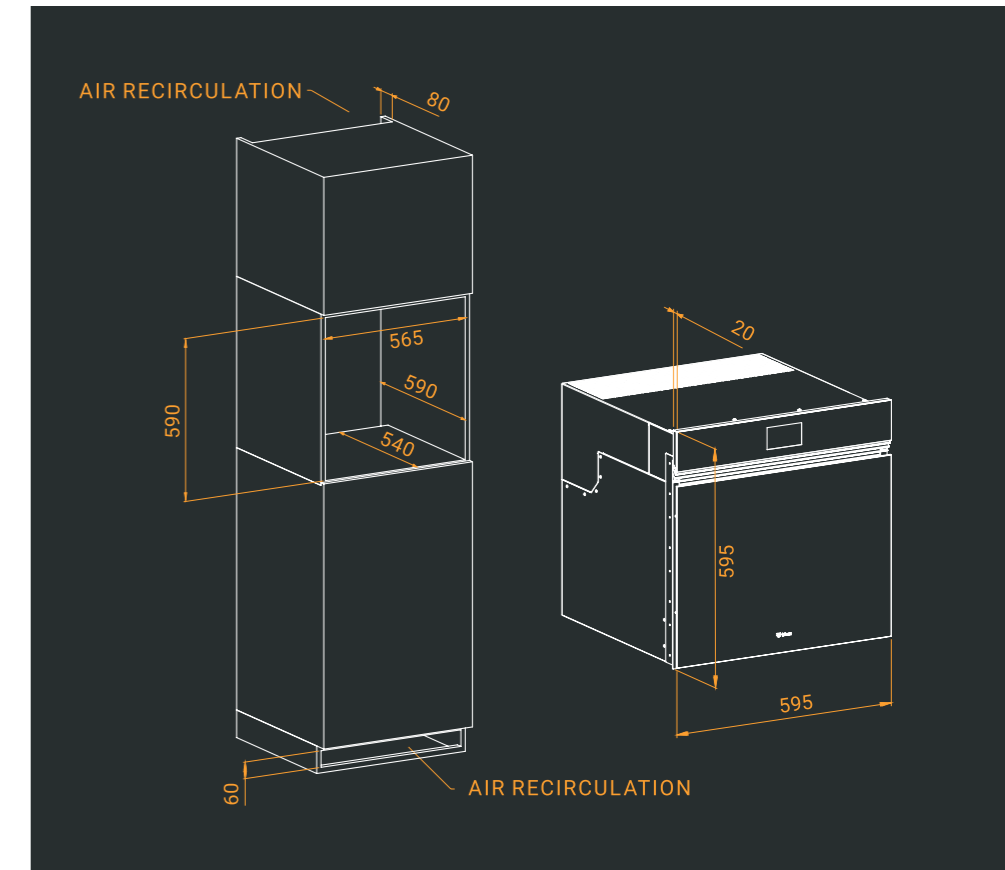

Built-in Freddy 45



L 595 mm
D 595 mm
H 450 mm
Capacity: 40 Litres

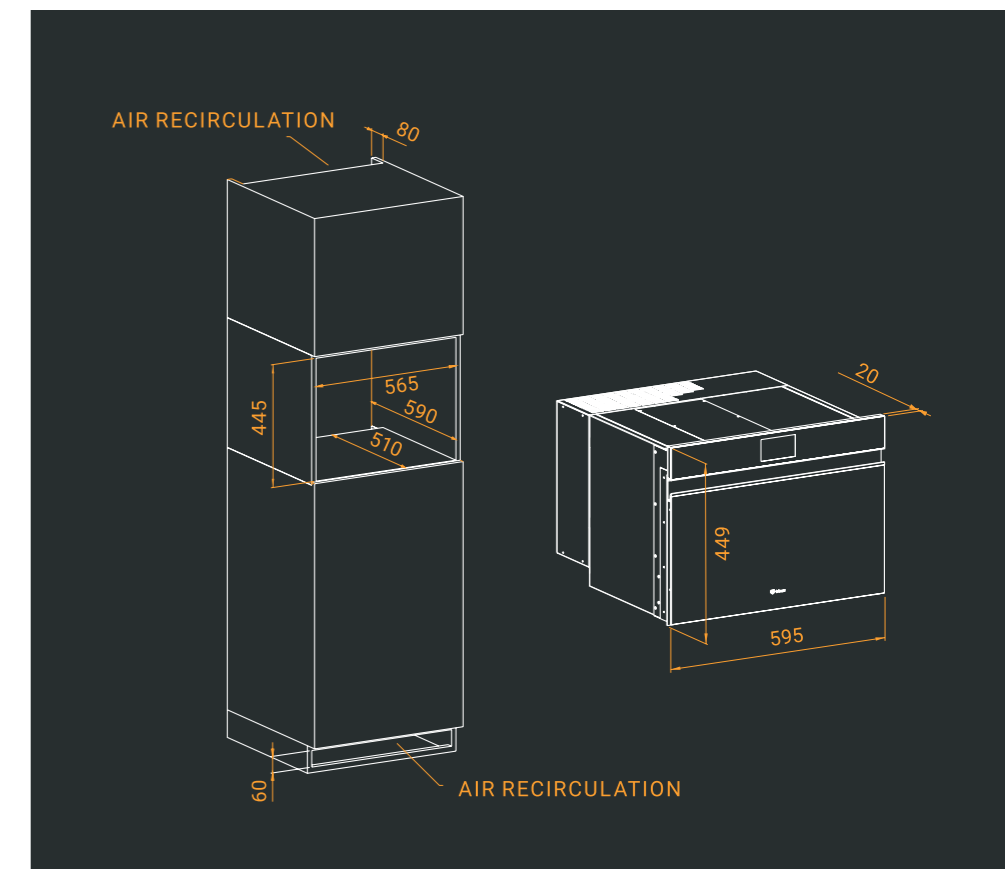

Fresco® Élite

Countertop multifunction blast chiller.

Fresco® Élite is used to quickly lower the temperature of food after cooking, to freeze and thaw rapidly and in a controlled manner. It also lets you meat and fish at low temperatures, leaven bread, pizza, and focaccia, and have your meal ready to be served when you get back home; store at the ideal temperature and chill wine and beverages. Fresco® Élite is available with door and dashboard in tempered Dark grey glass, and brushed stainless steel handle. Furthermore, Fresco® Élite has a mechanical door stop with maximum 160° opening.

TECHNICAL SPECIFICATIONS Fresco® Élite	
Blast chilling cycle yield (from +90 °C to +3 °C)	2,5 kg
Shock freezing cycle yield (from +90 °C to -18 °C)	2,5 kg
Voltage	220 - 240 V / 50 Hz
Max absorbed power	350 W
Total absorption	2.12 A
Refrigerant gas	R290
Net machine weight	33 kg
Grille capacity	2

Standard equipment: One stainless steel grille. / 100 ml disinfecting spray.

Finishes

External finishes in brushed stainless steel, door in tempered Dark grey glass, dashboard in tempered Dark grey glass, handle in brushed stainless steel, back in stainless steel.

Placement precautions

Ensure you leave at least 50 mm air gap at the sides and on the back. It is recommended to install the appliance away from heat sources, ovens or other appliances that produce heat. Provide for a Schuko plug for power supply.

Fresco® Élite



L 566 mm
D 380 mm
H 382 mm
(H 405 total including feet, H 23 mm)

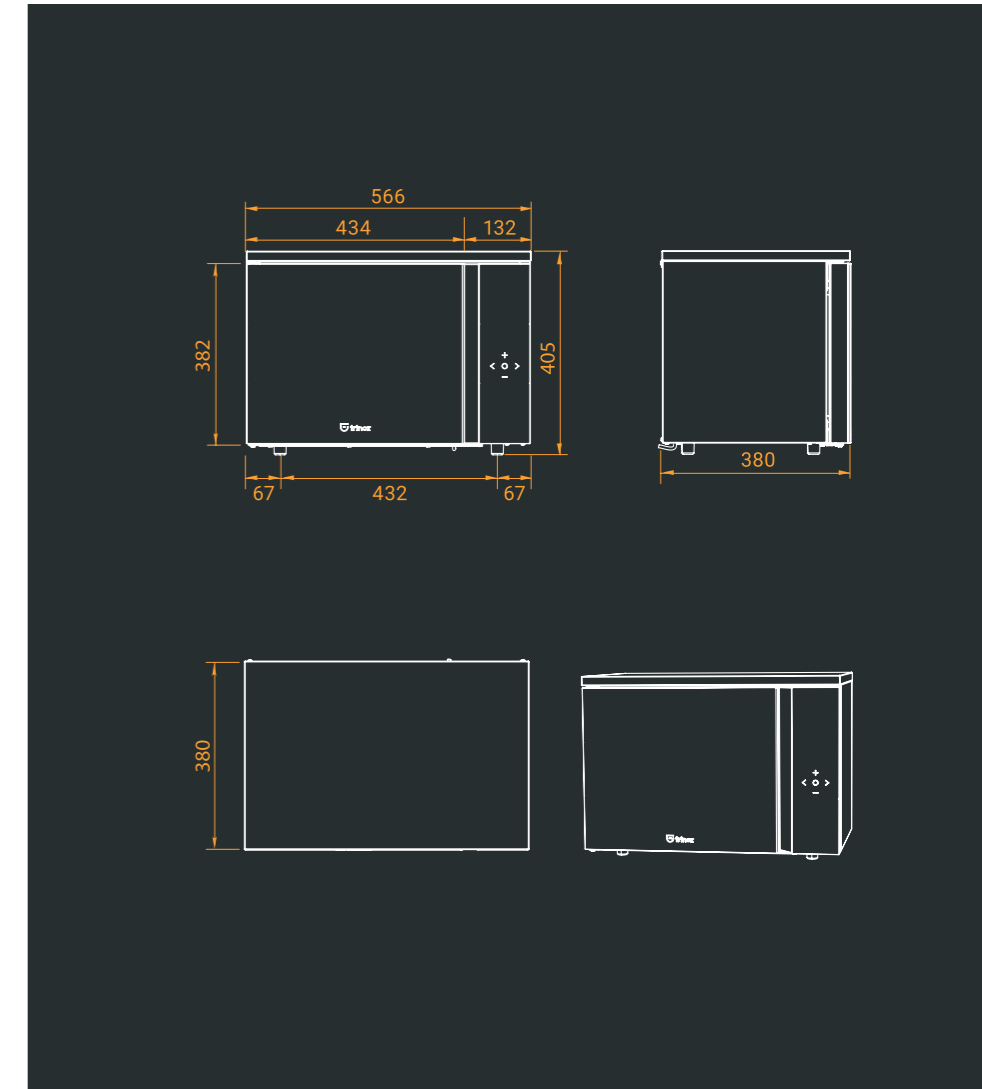

Zero

The built-in vacuum sealer that achieves extreme vacuum at 99,9%.

Built-in vacuum sealer.

It is available in three heights: 45, 36 or 15 cm.

The internal tank, made of AISI 304-18/10 stainless steel, can accommodate traditional Bormioli jars of the appropriate size or, using the special adapter supplied, can be connected to external containers. The tank depth is 145 mm for Zero 45, 145 mm for Zero 36, 92 mm for Zero 15.

Indispensable for sous-vide cooking, it increases up to 5 times the shelf life of food, either solid or liquid.

TECHNICAL SPECIFICATIONS	Zero 45	Zero 36	Zero 15
Vacuum pump	8 m ³ / h	8 m ³ / h	3 m ³ / h
Voltage	220 - 240 V / 50 - 60 Hz	220 - 240 V / 50 - 60 Hz	220 - 240 V / 50 - 60 Hz
Max absorbed power	500 W	500 W	360 W
Maximum sealable width	300 mm	300 mm	300 mm
Vacuum capacity	99.9 %	99.9 %	99.9 %
Residual vacuum	< 10 mbar	< 10 mbar	< 10 mbar
STAINLESS steel tank	AISI 304 - 18/10	AISI 304 - 18/10	AISI 304 - 18/10
STAINLESS steel construction	AISI 304 - 18/10	AISI 304 - 18/10	AISI 304 - 18/10
Net machine weight	48 kg	45 kg	36 kg
Vacuum chamber volume	14 litres	14 litres	7 litres

Standard equipment: Assorted vacuum bags (25 bags sized 200 x 250mm and 25 bags sized 250 x 300mm), ideal for freezing, preservation and sous-vide cooking of food at low temperatures / Connecting tube for external vacuum. / Polyethylene filler support.

Finishes

It is possible to customise the finish of all Zero models: brushed steel, black glass and De Castelli. Furthermore, they are available with the kitchen door finish required by the customer and in RAL colours. (See page 84).

Assembly precautions

The household appliance comes with a connection cable (length 1.5 m). Provide for the Schuko plug behind the appliance.

Built-in Zero 45



L 595 mm
D 575 mm
H 450 mm

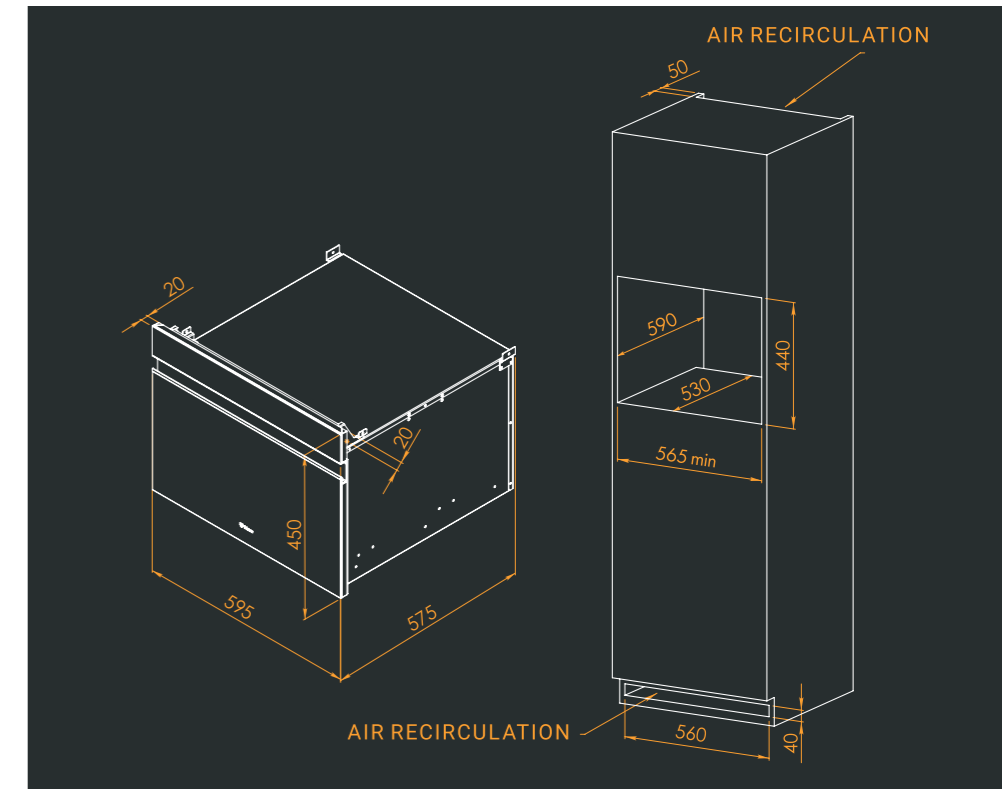

Built-in Zero 36



L 595 mm
D 576 mm
H 360 mm

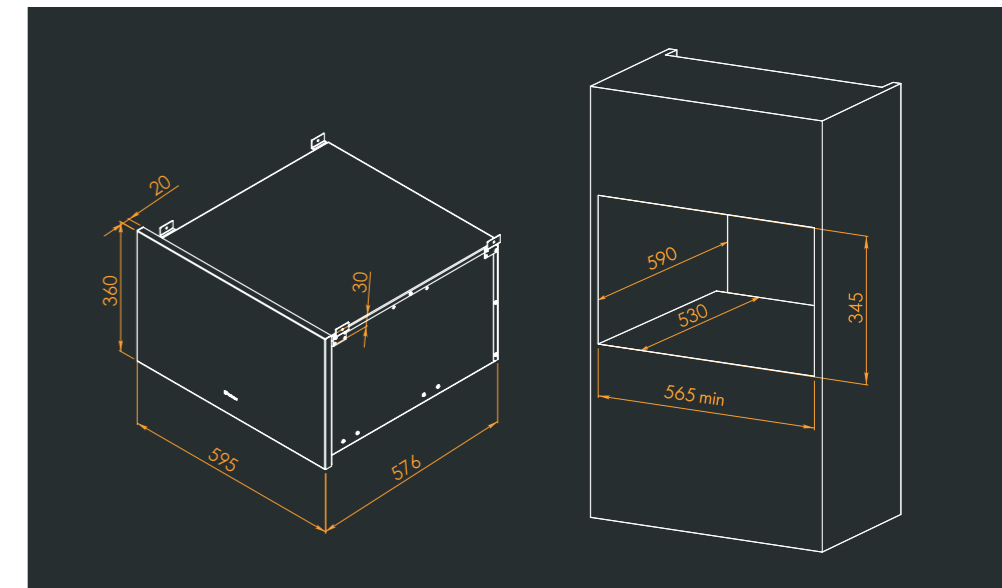

Built-in Zero 15



L 595 mm
D 576 mm
H 140 mm

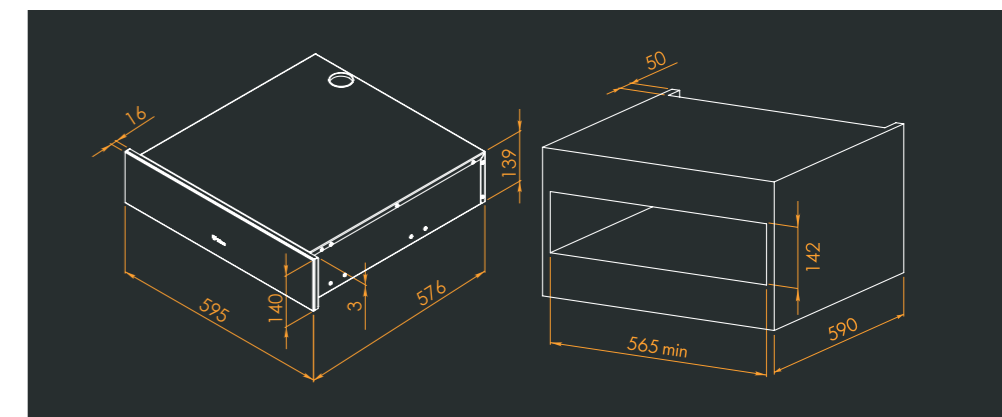

Wave Hot&Cold

Every type of water, when you want it, at home.

The built-in water dispenser.

Wave dispenses 4 types of water: microfiltered water at room temperature, cold microfiltered water, sparkling cold microfiltered water and hot water at 85 °C.
Wave is available at a height of 45 cm for built-in installation.
Wave controls have soft-touch technology, without any buttons.
Wave is designed both for the use of disposable CO₂ cylinders (standard) and for external rechargeable cylinders.
The carbon dioxide consumption depends on how sparkling you want the water. Wave is available in stainless steel, black glass and De Castelli material.

TECHNICAL SPECIFICATIONS Wave 45 Hot&Cold	
Compressor power	1/11Hp
Voltage	230 V - 1Ph - 50/60 Hz
Production of cold and sparkling water	15 l/h
Adjustable gassing system	min - max 2 ÷ 3.5 bar
Adjustable cold water temperature	from 5 to 12 °C
Hot water temperature	85 °C +/- 1 °C
Water inlet pressure	2 ÷ 3.5 bar
Max absorbed power	810 W
Disposable CO ₂ cylinder capacity	600 g
Cold line (hot line) purifying filter service life	2.700 Lt / 1 year (1700 Lt / 6 months)
Net built-in machine weight	35 kg
Refrigerant gas	R600

Standard equipment: Certified NSF class 1 filter (cold line) / Hot water filter.

Option: 600 g disposable CO₂ cylinder / Rechargeable 1 kg CO₂ cylinder kit including connection pipe / Rechargeable 4 kg CO₂ cylinder kit including connection pipe.

Finishes

It is possible to customise the finish of all Wave models: brushed steel, black glass, front panels in various colours and De Castelli finishes. (See page 84)

Assembly precautions

For proper use, the purification filters and the CO₂ cylinder need to be checked. The filter (cold line) inside the appliance has a service life of 2700 litres or 1 year. The filter (hot line) has a service life of 1700 litres.

For appropriate operation of the household appliance, the filters must always be in good condition. When the filters run out, the water supply is not interrupted, but a warning signal to change the filter is emitted.

Replacement is recommended between 6 months and 1 year, according to the water hardness and the quantity of hot water dispensed.

Built-in Wave Hot&Cold 45



L 595 mm
D 547 mm
H 450 mm

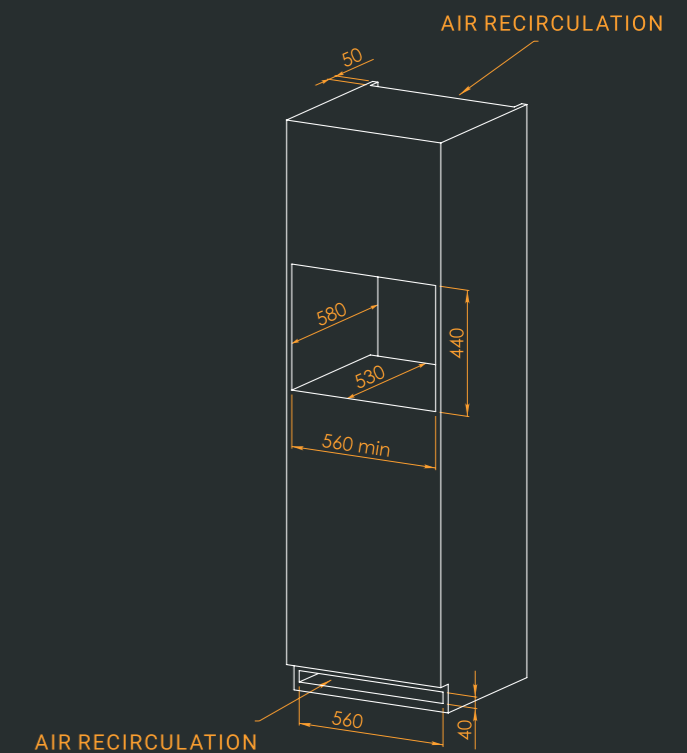
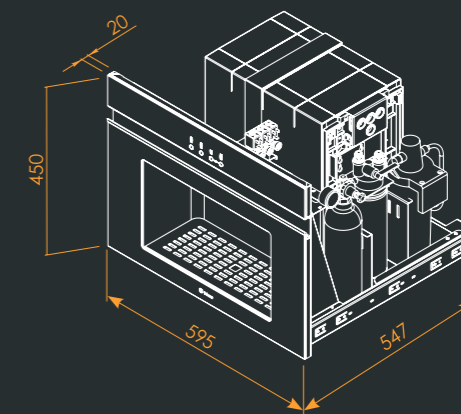

Vinoteca

Vinoteca provides perfect storage for the most valuable wines.

The wine cabinet.

Available in 3-dimension built-in version, with black glass finish. Vinoteca 60 is equipped with 3 sliding beech shelves (2 shelves to hold Bordeaux bottles, 1 shelf to hold Magnum bottles), while Vinoteca 45 has 2 sliding beech shelves (to hold Bordeaux bottles).

The electronic control panel is set on the inside and the temperature can be read on the touchpad electronic display. Vinoteca is fitted with a second-generation push-open system and the adjustable LED lighting creates an elegant display ambiance.

TECHNICAL SPECIFICATIONS	Dual-temperature Vinoteca 60	Single-temperature Vinoteca 45	Single-temperature Vinoteca 15
Power	100 W	85 W	130 W
Voltage	220 / 240 V - 50 Hz	220 / 240 V - 50 Hz	220 / 240 V - 50 Hz
Total absorption	1.2 A	1.2 A	0.8 A
Consumption	0.27 kWh / 24 h	0.19 kWh / 24 h	0.24 kWh / 24 h
Energy efficiency class	F	E	F
Annual energy consumption	99 kWh	69 kWh	88 kWh
Net machine weight	42 kg	34 kg	19 kg
Temperature range	5 °C - 20 °C	5 °C - 20 °C	5 °C - 20 °C

Standard equipment: 3 sliding shelves for Vinoteca 60 (2 shelves for Bordeaux bottles - 1 shelf for Magnum bottles) / 2 sliding shelves for Vinoteca 45 (for Bordeaux bottles).

Finishes

Vinoteca is only available in black glass finish.

Assembly precautions

Make sure to leave an air gap of at least 50 mm at the back of the recessed compartment as shown in the drawing.

It is recommended to install the appliance away from heat sources, ovens or appliances generating heat or moisture. After transport, place the appliance in an upright position and wait at least 3 hours before connecting it to the electrical installation. The appliance is supplied with power supply connection cable complete with Schuko plug (length 1.30 m).

Built-in Vinoteca 60



L 595 mm
D 557 mm
H 595 mm

Built-in Vinoteca 45



L 595 mm
D 557 mm
H 455 mm

Built-in Vinoteca 15



L 595 mm
D 557 mm
H 141 mm

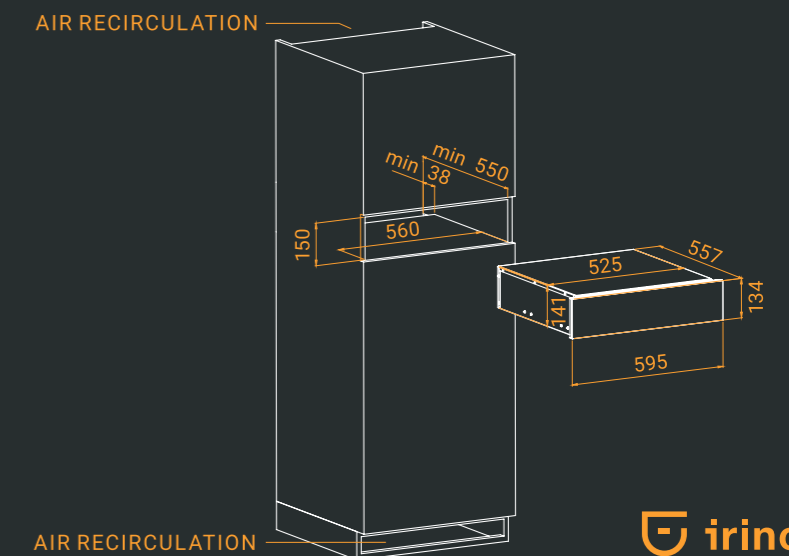
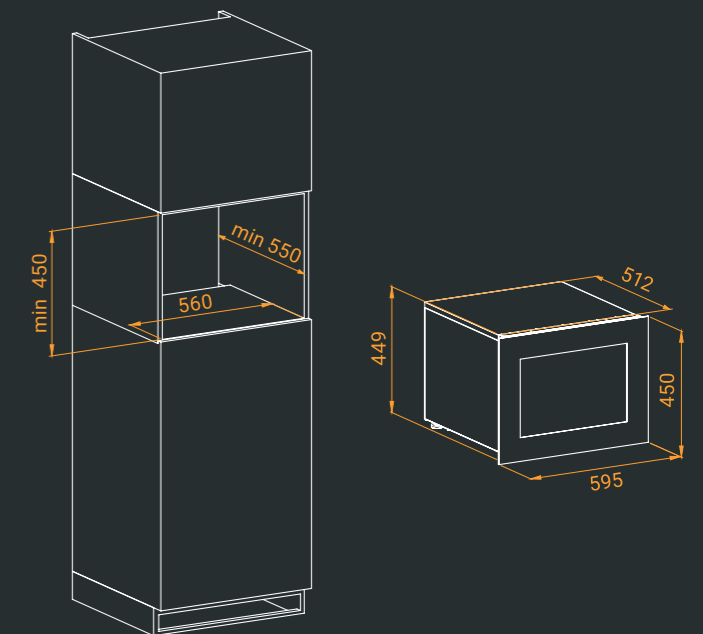
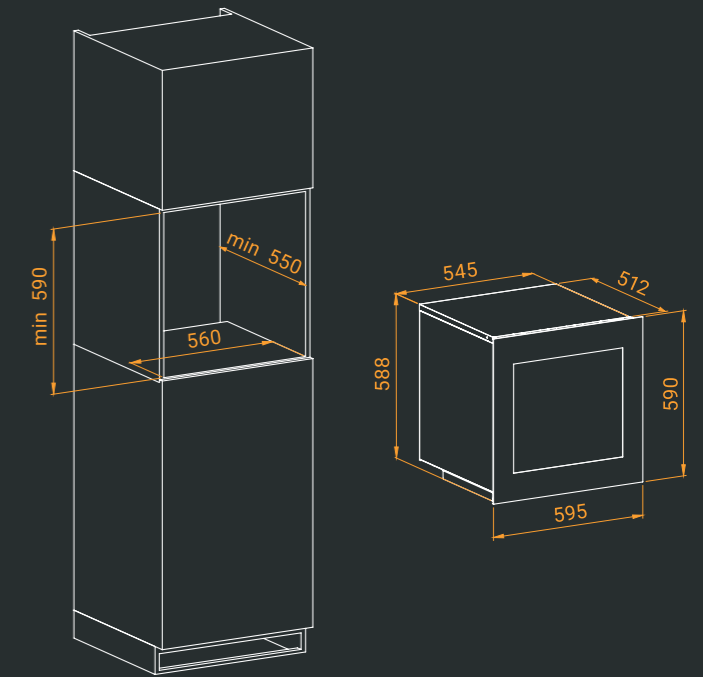

Available and customisable finishes.

It is possible to customise the finish of all products in the Irinox Home line by choosing from a wide range of materials: brushed steel, black glass and De Castelli.

Freddy and **Zero** are available with the kitchen door finish required by the customer and in RAL colours. Vinoteca/Vinoteca is only available in black glass finish.

FREDDY 60:

- BLACK GLASS/BLACK DASHBOARD
- BRUSHED STEEL/BRUSHED STEEL DASHBOARD
- NEUTRAL/BLACK DASHBOARD

FREDDY 45:

- BLACK GLASS/ANODISED STEEL HANDLE/BLACK DASHBOARD
- BRUSHED STEEL/BLACK HANDLE/BRUSHED STEEL DASHBOARD
- BLACK GLASS/BLACK HANDLE/BLACK DASHBOARD
- BRUSHED STEEL/ANODISED STEEL HANDLE/BRUSHED STEEL DASHBOARD
- NEUTRAL/BLACK HANDLE/BLACK DASHBOARD

* DE CASTELLI FINISHES ON REQUEST H60
* DE CASTELLI FINISHES ON REQUEST H45

ZERO 45:

- BRUSHED STEEL/BLACK HANDLE
- BLACK GLASS/ANODISED STEEL HANDLE
- BLACK GLASS/BLACK HANDLE
- BRUSHED STEEL/ANODISED STEEL HANDLE
- NEUTRAL CUSTOMISABLE WITH BLACK DASHBOARD - BLACK HANDLE

ZERO 36:

- BRUSHED STEEL
- BLACK GLASS
- NEUTRAL CUSTOMISABLE

ZERO 15:

- BRUSHED STEEL
- BLACK GLASS
- NEUTRAL CUSTOMISABLE
- MIRROR GLASS

* DE CASTELLI FINISHES ON REQUEST H45
* DE CASTELLI FINISHES ON REQUEST H36
* DE CASTELLI FINISHES ON REQUEST H15

WAVE HOT&COLD 45:

- BLACK GLASS - ANODISED STEEL HANDLE
- BRUSHED STEEL-BLACK HANDLE
- NEUTRAL CUSTOMISABLE WITH BLACK DASHBOARD - BLACK HANDLE
- BLACK GLASS-BLACK HANDLE
- BRUSHED STEEL - ANODISED STEEL HANDLE

* DE CASTELLI FINISHES ON REQUEST

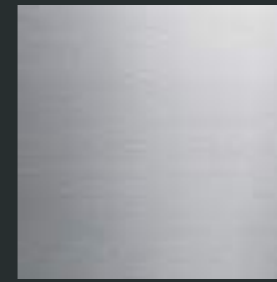

Brushed steel finish

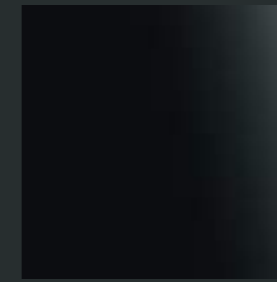

Black glass finish



Neutral finish - kitchen cabinet door

Finish DE CASTELLI

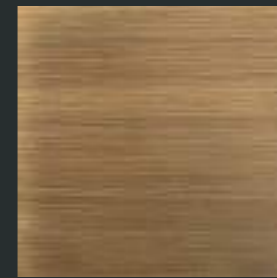

Délabré Striped Brass



Délabré Oxidised Iron

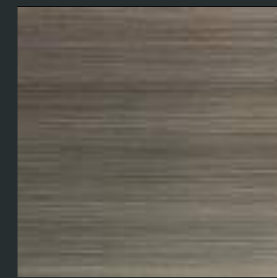

Délabré Brass

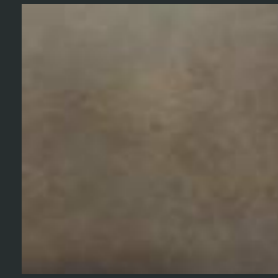

Délabré Striped Copper



Délabré Striped Iron

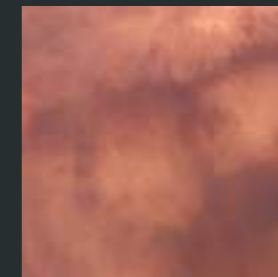

Délabré Copper

Customisable front panel

Freddy 60

L 595 mm
H 452 mm
D 4 mm
weight min 1.7 kg / max 2.7 kg

Freddy 45

L 595 mm
H 320.8 mm
D 4 mm
weight min 1.3 kg / max 2 kg

Zero 45

L 595 mm x H 326,7 mm
D 5 mm
weight min 1.2 kg / max 2.0 kg

Zero 36

L 595 mm x H 358 mm
D 5 mm
weight min 1 kg / max 2 kg

Zero 15

L 595 mm x H 140 mm
D 5 mm
weight min 0.5 kg / max 1 kg

Wave Hot&Cold 45

L 595 mm x H 326,7 mm
D 4 mm
weight min 1.2 kg / max 2.0 kg

The images of the finishes are for illustrative purposes only and may not fully reflect the product features.



Irinnox SpA - Società Benefit | B Corp

Via Caduti nei Lager, 1
31015 Conegliano (TV) - Italy
+39 0438 2020
www.irinoxhome.com
info@irinoxhome.com



Concept and art direction
claim.brandindustry

Photography
Fotografica - Riccardo Munarin

Food Styling
L'ultima fetta - Lucia Carniel

Special thanks
Arrital Cucine
Tognana Porcellane S.p.A.



www.irinoxhome.com